

OCHP

OPEN CLEARING
HOUSE PROTOCOL

Protocol Version 1.2

Protocol Status Release

Document Version 0.18

Document Date June 17, 2014

Protocol Release Log

Versions		Date	Author	Comment
Prot.	Doc.			
0.1	0.1	28-02-2012	A. Pfeiffer, C. Pestel, smartlab	Concept, Functional specification
0.2	0.4	21-05-2012	C. Pestel, smartlab; L. Janssen, Liandon	VAS data added
1.0	0.15	12-12-2013	S. Schilling, smartlab	Use-case driven structure; Delta-Synchronization; Live-Authorization; CDR-Validation; Alignment to standardization and market development.
1.2	0.18	17-06-2014	S. Schilling, smartlab	Live Status Interface and further enhancements from market requirements.

Document Version Log

Doc-V.	Date	Author	Comment
0.1	28-02-2012	A. Pfeiffer, C. Pestel, smartlab	Concept, Functional specification
⋮	⋮	⋮	⋮
0.12	24-10-2013	S. Schilling, smartlab	Alignment to market terminology. Simplification.
0.13	27-11-2013	S. Schilling, smartlab	Consolidation of stakeholder's feedback.
0.14	09-12-2013	S. Schilling, smartlab	Use-case driven structure; Delta-Synchronization; Live-Authorization; CDR-Validation
0.15	12-12-2013	A. Wargers, e-laad; S. Schilling, smartlab	Added list of plug types
0.16	31-03-2014	S. Schilling, smartlab	Transferred document to latex
0.17	30-05-2014	S. Schilling, smartlab	General enhancements during eCHS development phase
0.18	17-06-2014	S. Schilling, smartlab	Added more information for implementation

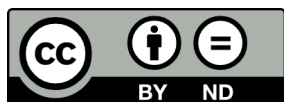

© smartlab, bluecorner.be, e-laad.nl 2012–2014

This work is licensed under the Creative Commons Attribution-NonDerivatives 4.0 International License. To view a copy of this license, visit <http://creativecommons.org/licenses/by-nd/4.0/>.

Contents

1	Introduction	8
1.1	Primary Stakeholders Electric Vehicles	8
1.1.1	Electric Vehicle User (EV User)	9
1.1.2	Electric Vehicle Service Provider (EVSP)	9
1.1.3	Electric Vehicle Supply Equipment Operator (EVSE Operator)	9
1.1.4	Navigation Service Provider (NSP)	9
1.1.5	Charging Session	10
1.2	Clearing House	10
1.3	Clearing House functionality	11
1.4	Functional principles of an EV Clearing House	12
2	CH-Partner Interface description	14
2.1	Exchange Authorisation Data	14
2.1.1	Upload own authorisation data (roaming list) to the CHS	14
2.1.2	Update own authorisation data (roaming list) in the CHS	15
2.1.3	Download global roaming authorisation data from CHS	15
2.1.4	Download updates in global roaming authorisation data from CHS	15
2.2	Exchange Charge Data	15
2.2.1	Upload Charge Data Records	16
2.2.2	Process Charge Data Records	16
2.3	Exchange Charge Point Information	17
2.3.1	Upload own charge point information to the CHS	17
2.3.2	Download global charge point information from the CHS	17
2.4	Live Request for a single authorization	17
2.4.1	Request the CHS to authorize one single token for roaming	17
2.5	Live Status Interface	18
2.5.1	Update the live status of the own stations in the CHS	18
2.5.2	Download global live status information from the CHS	19
3	Messages	21
3.1	Messages for the Exchange of Authorisation Data	21
3.1.1	GetRoamingAuthorisationList.req	21
3.1.2	GetRoamingAuthorisationList.conf	21
3.1.3	SetRoamingAuthorisationList.req	21
3.1.4	SetRoamingAuthorisationList.conf	21
3.1.5	GetRoamingAuthorisationListUpdates.req	21
3.1.6	GetRoamingAuthorisationListUpdates.conf	22
3.1.7	UpdateRoamingAuthorisationList.req	22
3.1.8	UpdateRoamingAuthorisationList.conf	22
3.2	Messages for the Exchange of Charge Data	22
3.2.1	GetCDRs.req	22
3.2.2	GetCDRs.conf	23
3.2.3	AddCDRs.req	23
3.2.4	AddCDRs.conf	23

3.2.5	ConfirmCDRs.req	23
3.2.6	ConfirmCDRs.conf	23
3.3	Messages for the Exchange of Charge Point Information	24
3.3.1	GetChargePointList.req	24
3.3.2	GetChargePointList.conf	24
3.3.3	SetChargePointList.req	24
3.3.4	SetChargePointList.conf	24
3.3.5	GetChargePointListUpdates.req	24
3.3.6	GetChargePointListUpdates.conf	25
3.3.7	UpdateChargePointList.req	25
3.3.8	UpdateChargePointList.conf	25
3.4	Messages for live authorisation	25
3.4.1	RequestLiveRoamingAuthorisation.req	25
3.4.2	RequestLiveRoamingAuthorisation.conf	26
3.5	Messages for the Live Status Interface	26
3.5.1	UpdateStatus.req	26
3.5.2	UpdateStatus.conf	26
3.5.3	GetStatus.req	26
3.5.4	GetStatus.conf	27
4	Types	28
4.1	General Types	28
4.1.1	Result	28
4.1.2	ResultCodeType	28
4.1.3	DateTimeType	28
4.1.4	LocalDateTimeType	28
4.2	Types for the Exchange of Authorisation Data	29
4.2.1	ContractId (or EVCO-ID)	29
4.2.2	EmtId	31
4.2.3	tokenType	31
4.2.4	tokenSubType	31
4.2.5	tokenRepresentation	31
4.2.6	RoamingAuthorisationInfo	32
4.3	Types for the Exchange of Charge Data	32
4.3.1	BillingItemType	32
4.3.2	CdrPeriodType	32
4.3.3	CdrStatusType	34
4.3.4	CDRInfo	34
4.4	Types for the Exchange of Charge Point Information	35
4.4.1	EvseId	35
4.4.2	evseImageUrlType	36
4.4.3	ImageClass	37
4.4.4	GeoPointType	38
4.4.5	ConnectorStandard	38
4.4.6	ConnectorFormat	39
4.4.7	ConnectorType	39

4.4.8	AuthMethodType	39
4.4.9	ChargePointStatusType	40
4.4.10	ChargePointScheduleType	40
4.4.11	HoursType	40
4.4.12	RegularHoursType	41
4.4.13	ExceptionalPeriodType	42
4.4.14	ParkingRestrictionType	42
4.4.15	ChargePointInfo	42
4.5	Types for live authorisation	45
4.5.1	LiveAuthId	45
4.6	Types for the Live Status Interface	46
4.6.1	MajorType	46
4.6.2	MinorType	46
4.6.3	EvseStatusType	46
5	Binding to Transport Protocol	47
5.1	User Identification	47
6	Annexes	48
6.1	ID Validation and Transformation Tools	48
6.1.1	Regular expression for EVSE-ID validation	48
6.1.2	Regular expression for Contract-ID validation	48
6.1.3	Regular expression for Contract-ID normalization	48
6.2	List of examples for valid Contract-Ids	49
6.3	Data Field Mapping to OCPP	50
6.3.1	Connector Types	50
6.4	EVSE Infrastructure Model	51
6.4.1	Data Model Structure	51
6.4.2	Examples	52
6.5	Charge Point Information Filtering	56

Preface

This document defines a standard interface between different parties in the market of electric vehicle charging infrastructure and a clearing house that provides a common data routing and exchange platform for all these market shareholders.

Document Versioning

The versions of this document refer to the non-functional or proposed enhancements and are not to be confused with the derived protocol states labelled by the protocol version numeration. To illustrate this, figure 1 shows the development process of this protocol.

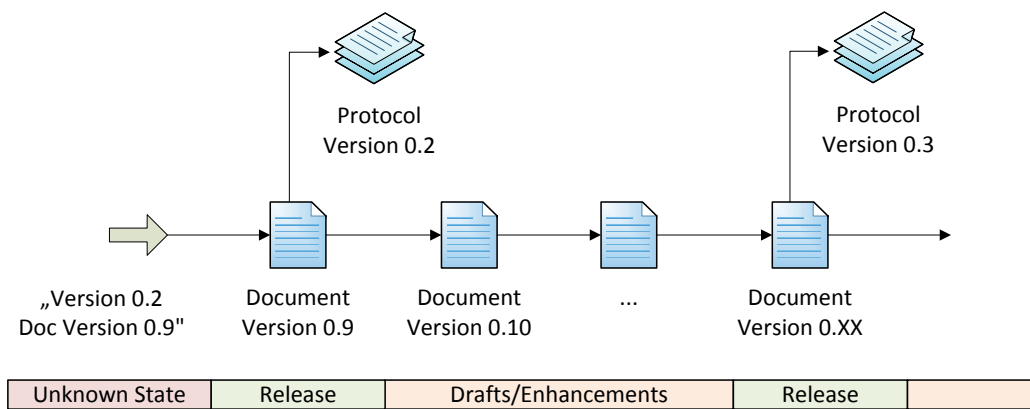

Figure 1: Protocol Versioning

Conventions

The key words *must*, *must not*, *required*, *shall*, *shall not*, *should*, *should not*, *recommended*, *may* and *optional* in this document are to be interpreted as described in RFC 2119.

The cardinality is defined by the indicators *, +, ? and 1, where the last one is the default. The meaning and mapping to XML syntax is as follows:

Meaning	XML Schema	DTD
At most one	MINOCCURS="0" MAXOCCURS="1"	?
one or more	MINOCCURS="1" MAXOCCURS="UNBOUNDED"	+
zero or more	MINOCCURS="0" MAXOCCURS="UNBOUNDED"	*
exactly one	(default)	1

For some data fields a Regular Expression is provided as an additional but very precise definition of the data format.

Abbreviations

Abbreviation	Meaning
CDR	Charge Detail Record
CH	Clearing House
CHS	Clearing House System
CMS	Charge Point Management System
Contract-ID	Contract (or Account) Identifier
EMP	Electric Mobility Provider
EMT-ID	Electric Mobility Token Identifier
EV	Electrical Vehicle
EVCO-ID	Electrical Vehicle Contract Identifier
EVSE	Electrical Vehicle Supply Equipment
EVSE-ID	Electrical Vehicle Supply Equipment Identifier
EVSE-Op	EVSE Operator
EVSP	Electric Vehicle Service Provider
ID	Identifier
MDM	Master Data Management System
NSP	Navigation Service Provider
OCHP	Open Clearing House Protocol
PDU	Protocol Data Unit
RA	Roaming Authorisation
RFID	Radio-frequency identification
VAS	Value Added Service

1 Introduction

1.1 Primary Stakeholders Electric Vehicles

The purpose of the Open Clearing House Protocol is to connect market actors in the field of electric mobility charging infrastructure. The different relevant market roles are as shown in figure 2:

1. The *EV user* of the overall system - a human charging an electric car via the connected infrastructure, having a direct or indirect service contract with an EVSP.
2. The *EVSP* (Electric Vehicle Service Provider) - granting access to charging stations and thus offering services to the contracted EV user. The service offer is supported by the market roles EVSE Operator and NSP.
3. The *EVSE Operator* (Electric Vehicle Supply Equipment Operator) - operating charging stations.
4. The *NSP* (Navigation Service Provider) - offering relevant navigation services to the EV user.
5. The *Clearing House Operator* - running a software platform called Clearing House to enable data exchange between the market roles (2) to (4).

In the context of a clearing house system the market roles (2) to (4) are referred as *partners*, the role (5) is called *administrator*. The role (1) is not explicitly known to the system. The role of a clearing house in terms of this document is to facilitate the exchange of roaming authorisations, charge point information and charge detail records between the market participants. Other clearing houses and local networks might serve the same purpose on a different scale/region or with different partners. The connection to other clearing houses is out of scope in the current state. The market roles are defined in the following section. One company however might fulfil one or more market roles. The contracts between each actor and the data routing are part of the clearing house's business logic and out of scope for this protocol description.

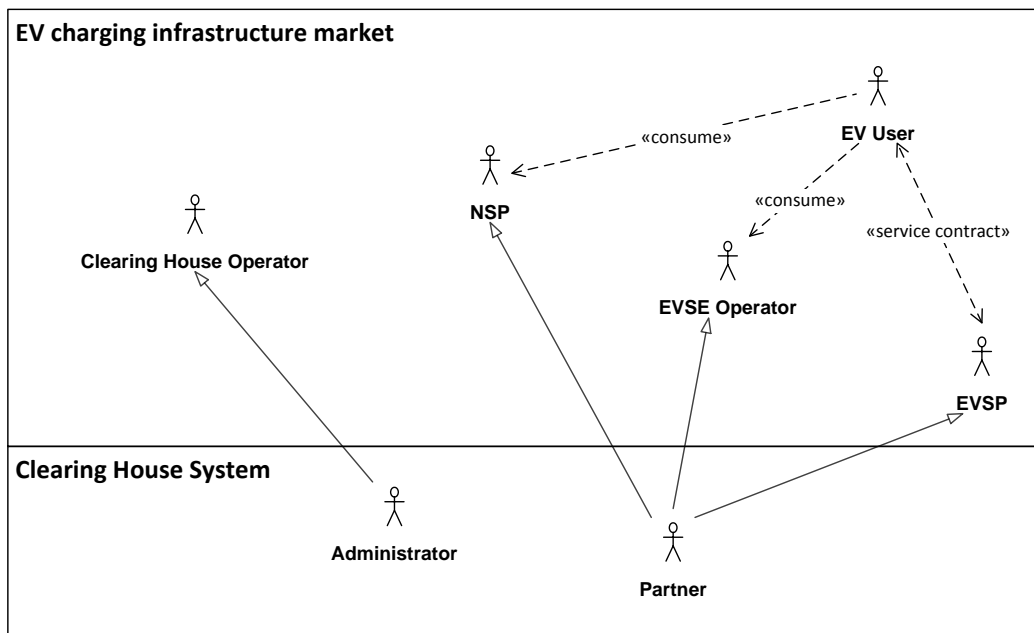

Figure 2: EV charging infrastructure market overview

1.1.1 Electric Vehicle User (EV User)

The EV user has a direct or indirect service contract with an EVSP who grants access to a specified charging infrastructure of one or more EVSE Operators. The EV users identify themselves via an access token issued by the EVSP.

1.1.2 Electric Vehicle Service Provider (EVSP)

The EVSP operates as a contract party for the EV user. The EV Service Provider takes care of the EV user authentication and billing processes. The EV Service Provider provides the EV-customer authorization tokens (i.e. RFID-card, Certificates, ...) that give authorisation to use the charging stations of contracted EVSE Operators.

1.1.3 Electric Vehicle Supply Equipment Operator (EVSE Operator)

The EVSE operator operates as contract party for the EVSP. The charging stations (EVSE) of the EVSE operator are accessible by a specified set of EV users of the contracted EVSPs. The EVSP pays the EVSE operator for the charging services received by its contracted EV users.

1.1.4 Navigation Service Provider (NSP)

The NSP offers service towards the EV user for searching, locating and routing to EVSEs of the contracted EVSE operators. It therefore may have contracts with EVSE operators or EVSPs.

1.1.5 Charging Session

A charging session in the scope of this document is defined from the successful authorization of the user at the charge point. It is considered active until the successful authorized stop command was executed (figure 3) or the car was disconnected from the charge point manually (figure 4). This is considered a forced unauthorized ending.

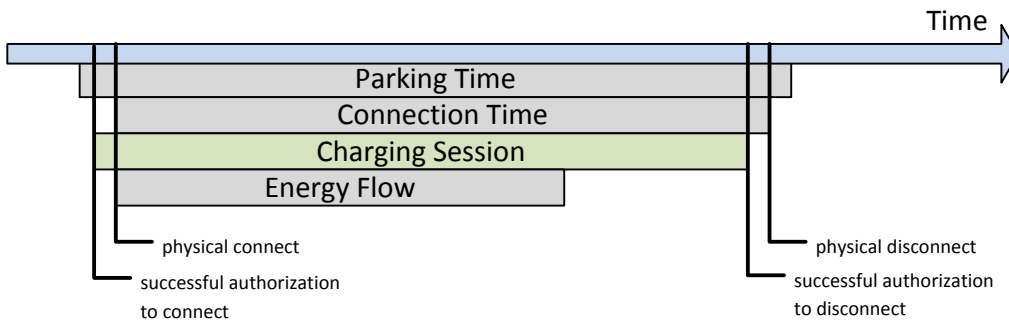

Figure 3: Example for an authorized end of a charging session

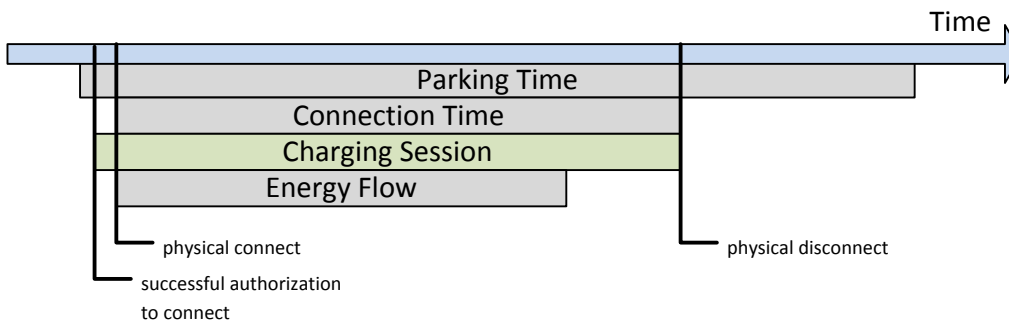

Figure 4: Example for a forced end of a charging session

1.2 Clearing House

The basic idea of a Clearing House is to enable the connected partners to roam with each other. The goal of roaming is that EV users can easily charge their electric vehicle on every charging station of different EVSE operators. With roaming support, provided by the Clearing House, the complexity of relationships can be reduced: from many-to-many bilateral partner connection towards a one-to-many connection between the Clearing House and the partners. Figure 5 illustrates the overall system overview of all partners with their systems and the clearing house system with the EV user as service consumer.

A different view to the implementation of the described role model gives figure 6. The clearing house provides here a central connection between the operator layer –

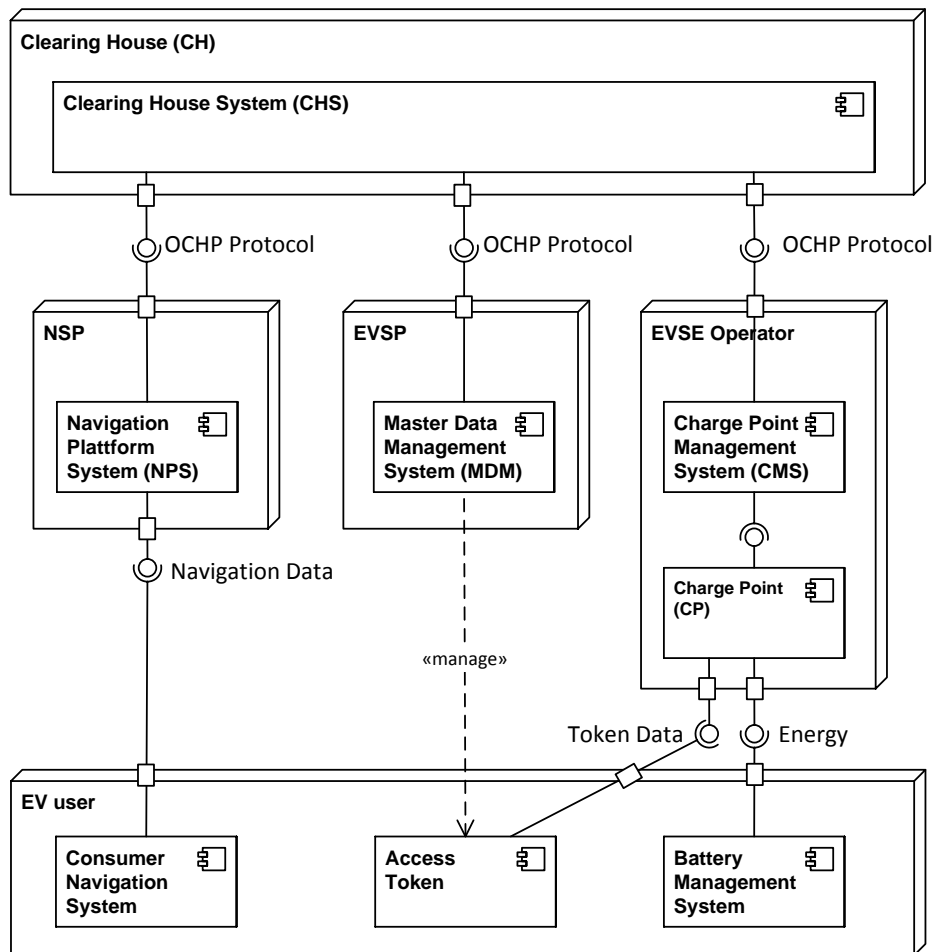

Figure 5: Global System Overview

where the charging stations are located – and the provider layer – where the users are. Direct connections of two roaming partners on the same layer are not necessary. Each partner operates a single connection to the clearing house from through which they get connected to multiple partners on the other layers.

Some of the partners might take two or more roles on different layers. For each of their roles a connection to the clearing house is necessary to connect to other roaming partners. The internal data connection between the distinct roles of one single partner might or might not be routed through the clearing house.

For the sake of simplification only two layers are shown in figure 6. The same principles apply to the navigation service layer. Also other additional clearing houses could exist in this model.

1.3 Clearing House functionality

An EV clearing house in the scope of this protocol facilitates the mutual exchange of roaming authorisations, charge data & charge point information between its partners.

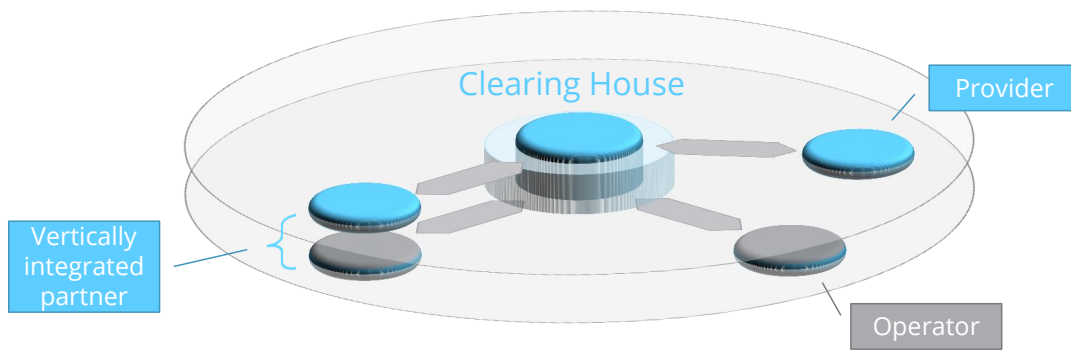

Figure 6: Layer model of clearing house connections

The formal act of clearing - as meant here - is the assignment of charge detail records to the corresponding EV Service Provider. The financial clearing has to be executed in a subsequent process step and is out of scope of the interface addressed by OCHP. However, the here defined data types are meant to be used as a base to calculate the payment request.

Normally the following steps are followed, (*highlighted* steps are in scope of OCHP):

1. *An EVSP (Partner A) uploads authorisation data of its EV users to the Clearing House (CH).*
2. *The EVSE operators that have a roaming contract with (A), download this authorisation data from the CH.*
3. The EVSE operators enable these authorisations to be used on their charge points.
4. The EV users of partner (A) can now charge their electric vehicles at all charge points of the EVSE operators named in step 2.
5. *The EVSE operator uploads the charge data (using Charge Detail Records) to the CH.*
6. *This charge data is then routed by the CH towards partner (A) using OCHP.*
7. Partner (A) pays the roaming partner for the charging action done by its customer.
8. Partner (A) bills its customer.

1.4 Functional principles of an EV Clearing House

As an intermediate between two independent roaming partners, a clearing house serves to simplify and unify the data connection. There are few main principles, the business logic of a clearing house for electric mobility should follow. Those basic rules are:

Transparency The existence of a clearing house should be completely transparent for the EV user. The roaming connection between an operator and a provider may or may not be routed through a clearing house.

Independence Roaming connections between two roaming partners and their business models or tariffs should not be influenced by the logic of the clearing house.

Anonymity The clearing house should require as little private user data as possible.

OCHP supports those basic principles and aims to be capable to any business model following them.

2 CH-Partner Interface description

The interfaces between the system of the Clearing House and systems of the different partners consist of the four following components:

1. Exchange of Authorisation Data (Roaming Authorisations, RoamingAuthorisationInfo)
2. Exchange of Charge Data, the raw billing data (Charge Detail Records, CDRInfo)
3. Exchange of Charge Point Information (Static POI data, ChargePointInfo)
4. Live Authorization Requests (Single-Token-Requests)

From the data flow perspective, each market role is a source or a sink for certain data types. Figure 7 gives an overview of the exchanged data types, their direction and their particular originating and consuming market role.

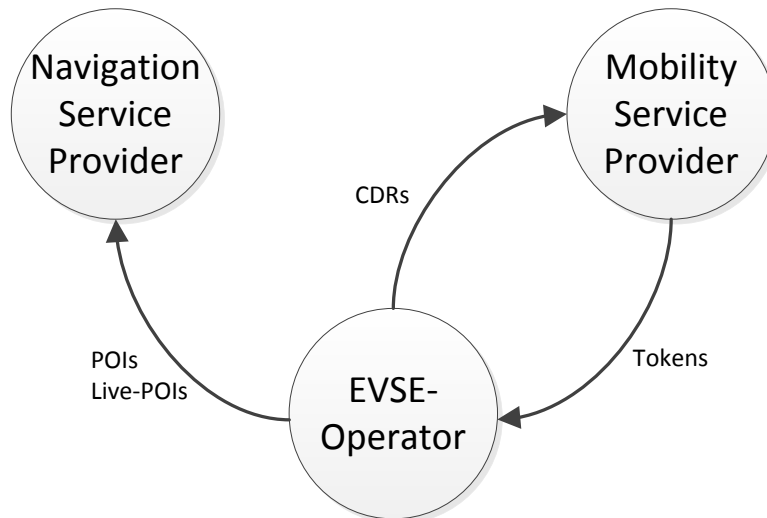

Figure 7: Data flow and direction overview

The exchange of data takes place via standardized web services.

2.1 Exchange Authorisation Data

2.1.1 Upload own authorisation data (roaming list) to the CHS

The MDM of each EVSP has to exchange the own authorisation data with the Clearing House to share that data with EVSE Operators. The upload of the own roaming list is done in the following way:

1. MDM sends the SetRoamingAuthorisationList.req PDU.
2. CHS responds with a SetRoamingAuthorisationList.conf PDU.

2.1.2 Update own authorisation data (roaming list) in the CHS

For later updates of authorization data from the MDM to the Clearing House and the EVSE Operators, only the changed entries (delta) have to be transferred. The updated roaming list entries have to be sent the following way:

1. MDM sends the UpdateRoamingAuthorisationList.req PDU.
2. CHS responds with a UpdateRoamingAuthorisationList.conf PDU.

2.1.3 Download global roaming authorisation data from CHS

A CMS downloads the global authorisation data repository from the CHS. The download of the global roaming list is done in the following way:

1. CMS sends the GetRoamingAuthorisationList.req PDU.
2. CHS responds with GetRoamingAuthorisationList.conf PDU.

2.1.4 Download updates in global roaming authorisation data from CHS

A CMS downloads the changes to the global authorisation data repository since the last synchronization from the CHS. The updates in the global roaming list can be done in the following way:

1. CMS sends the GetRoamingAuthorisationListUpdates.req PDU.
2. CHS responds with GetRoamingAuthorisationListUpdates.conf PDU.

2.2 Exchange Charge Data

The exchange of charge data is done by sending records containing all billing information from the EVSE-Operator to corresponding the EVSP. The data set is called Charge Detail Record (CDR). Each CDR contains a status value that reflects the processing state of the record within the clearing house roaming connection. The status must not be set directly by the roaming partners' systems. Figure 8 illustrates the status flow for each CDR.

CDR Validation Process In bilateral agreed intervals, the EVSE-Operator or CDR-”Originator” sends all relevant CDRs to the Clearing House. A basic plausibility check is performed by the Clearing House and determines if the CDRs can be accepted. Implausible CDRs will directly be sent back to the CDR-”Originator” and can be adjusted. A corrected version of the CDR can again be uploaded to the Clearing House with the next call. Already uploaded CDRs will have the status *new* set by the Clearing House. Plausible CDRs will be marked as *accepted* and sent to the EV Service Provider or CDR-”Owner” for approval.

The CDR-”Owner” downloads in bilateral agreed intervals the list of CDRs from all providers. After an internal validation check in the backend, the EVSP uploads a list of

approved and declined CDRs to the Clearing House. Approved CDRs will be marked as such and their status is set to *approved*. These CDRs will then be archived and are not available for download any more. Declined CDRs will be marked as *owner-declined*, an issue will be filed and the Clearing House will try to solve the issue. Upon manual revision the CDRs will be either marked as *approved* or *rejected* to be archived in the system. CDRs in status *owner-declined* are not available for download.

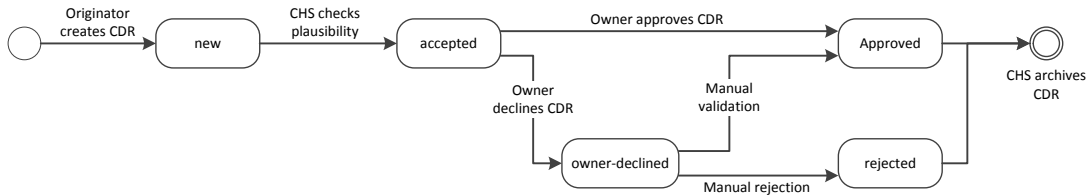

Figure 8: Status flow for CDRs

2.2.1 Upload Charge Data Records

Local roaming charge data records are sent from the CMS to the CHS. The upload has to be done in the following way:

1. CMS sends the AddCDRs.req PDU.
2. CHS responds with: AddCDRs.conf PDU.

2.2.2 Process Charge Data Records

Incoming roaming charge data records, held at the CHS are sent from the CHS to the MDM. Note that only CDRs that concern the particular EVSP are sent. The download has to be done in the following way:

1. MDM sends GetCDRs.req PDU.
2. CHS responds with a GetCDRs.conf PDU.
3. MDM confirms or declines single CDRs with ConfirmCDRs.req
4. CHS responds with a ConfirmCDRs.conf PDU.

Implementation All CDRs stay in the download queue until their successful download was confirmed by a call to ConfirmCDRs.req. Declined CDRs may be handled in a separate negotiation process as described before.

2.3 Exchange Charge Point Information

For user information and routing purpose detailed information about charge points can be exchanged via OCHP. The EVSE Operator sends this data towards the systems of Navigation Service Providers. Those systems may aggregate, sort and filter the data and provide it to the navigation services or devices through proprietary interfaces within the NSP ecosystem. Detailed information about the filtering of charge point information can be found in annex 6.5.

2.3.1 Upload own charge point information to the CHS

Each CMS has to upload its own Charge point information to the Clearing House. The upload of the own charge point information is done in the following way:

1. CMS sends the SetChargePointList.req PDU.
2. CHS responds with a SetChargePointList.conf PDU.

2.3.2 Download global charge point information from the CHS

A NPS downloads the global charge point information from the CHS. The download of the global charge point information is done in the following way:

1. NPS sends the GetChargePointList.req PDU.
2. CHS responds with GetChargePointList.conf PDU.

2.4 Live Request for a single authorization

Live requests are sent from the EVSE-Operator backend to the clearing house in the event that the local repository of authorization records was not synchronized from the clearing house. Figure 9 illustrates the steps during a charging session that is authorised live by the clearing house. During the authorisation for the start of the process the operator backend is requesting the clearing house via OCHP. The response contains the authorisation or rejection and a transaction ID. For the end of the charging process the operator backend is able to authorise the same token. For the later exchanged CDR the transaction ID of the single authorisation is to be used.

2.4.1 Request the CHS to authorize one single token for roaming

A CMS may request the Clearing House to authorize one single token for a charging session. The authorization is requested for a single EVSE-ID and a single token. Optional a ID for the single transaction can be added to track the issued CDR in the requester's numbering scheme. The request for authorization is done in the following way:

1. CMS sends the RequestLiveRoamingAuthorisation.req PDU.
2. CHS responds with a RequestLiveRoamingAuthorisation.conf PDU.

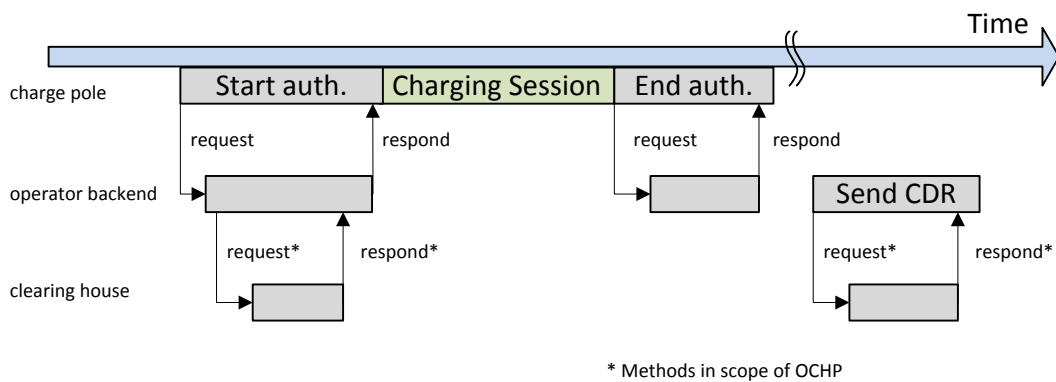

Figure 9: Message exchange for live authorisation requests for a single charging process.

2.5 Live Status Interface

As additional status information to the static POI data of the Charge Point Information, the Live Status Interface builds upon that. Thus, live status data does only contain the status information of each EVSE without further payload data. A additional time to live can be specified until the status information may be considered as actual. Overdue status information will be dropped by the CHS. The Navigation System Providers are asked to request the actual status for stations without valid status information. The current major and minor status of each EVSE shall be set following the decision flow in figure 10

Table 1 shows the relationship of the major and minor status values. Other combinations of the status values are must not be set.

Implementation Each status update from the sending operator must contain the major status and may contain a minor status for further details. Consuming Navigation System Providers must be able to process the three major status values. Optionally they may display the minor status and the ttl-value to the user.

The clearing house or every consuming system may drop status values with an expired ttl-value. The status of an EVSE must default to *unknown* in that case.

Consuming systems should request for new status updates whenever an loaded status value expires.

2.5.1 Update the live status of the own stations in the CHS

A CMS may update the current live status of individual charging stations in the Clearing House to allow roaming partners to receive those statuses. The live status update is done in the following way:

1. CMS sends the UpdateStatus.req PDU.
2. CHS responds with a UpdateStatus.conf PDU.

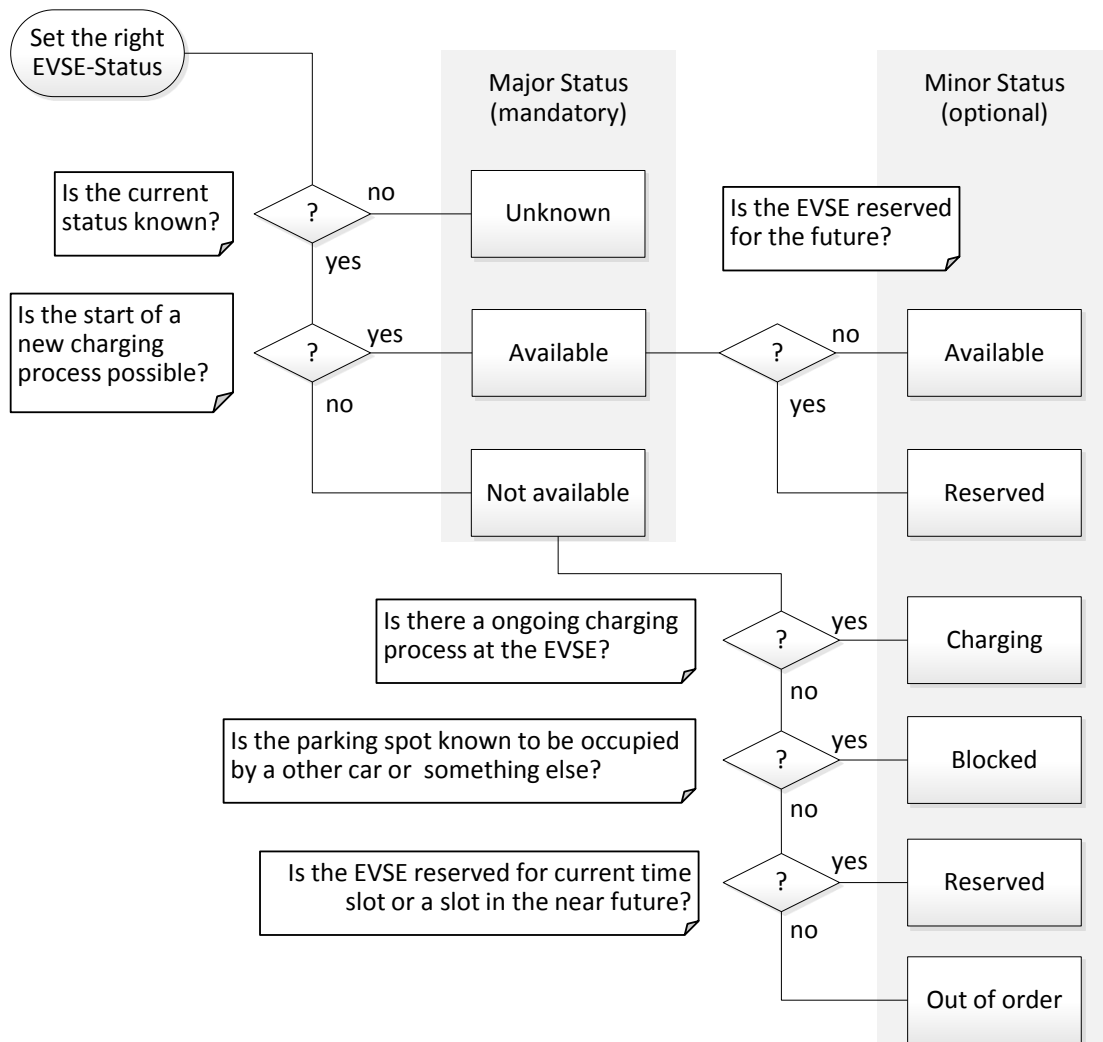

Figure 10: Status decision flow for EVSEs.

2.5.2 Download global live status information from the CHS

A NPS may receive the current live status of individual charging stations from the Clearing House. The live status download is done in the following way:

1. CMS sends the GetStatus.req PDU.
2. CHS responds with a GetStatus.conf PDU.

Major Status	Minor Status	Description
Unknown	n/a	Operator can not reliably determine the current status. TTL is set to the time the next status update is expected, normally in near future.
Available	Available	A new charging process can be started immediately. TTL is set to the near future, normally five minutes ahead.
Available	Reserved	A new charging process can be started immediately but there is a reservation in the future. TTL is set to a date until when new charging processes may be started. Usually the status will change than to <i>Not Available-Reserved</i> .
Not Available	Charging	Charging process ongoing, charge point occupied. No new charging process can be started. TTL is set to the expected end of the charging process. For example 20 minutes ahead for quick charging.
Not Available	Blocked	Parking spot occupied w/o ongoing charging process. This may be caused by a parked car that is not ambiguous to charge. TTL is set to a date in the near future.
Not Available	Reserved	Reserved for now or the near future, no new charging process may be started. TTL is set to the date the reservation will expire. Usually the status will change than to either <i>Not Available-Charging</i> or to <i>Available-Available</i> if the reservation was not used..
Not Available	Out Of Order	Unplanned or planned failure of the charge point. TTL is set to the expected end of the failure if known.

Table 1: Possible combination of live status values.

3 Messages

3.1 Messages for the Exchange of Authorisation Data

These messages are used for the purpose of the exchange of authorization data from an EVSP to an EVSE Operator.

3.1.1 GetRoamingAuthorisationList.req

This contains the field definition of the GetRoamingAuthorisationList.req sent by a partner's system to the CHS.

No fields are defined.

3.1.2 GetRoamingAuthorisationList.conf

This contains the field definition of the GetRoamingAuthorisationList.conf sent by the CHS as response to the GetRoamingAuthorisationList.req.

Field Name	Field Type	Card.	Description
result	Result	1	This contains the result of GetRoamingAuthorisationList.req.
roamingAuthorisationInfoArray	RoamingAuthorisationInfo	*	This contains the roaming authorisation records.

3.1.3 SetRoamingAuthorisationList.req

This contains the field definition of the SetRoamingAuthorisationList.req sent by a partner's system to the CHS.

Field Name	Field Type	Card.	Description
roamingAuthorisationInfoArray	RoamingAuthorisationInfo	+	This contains the roaming authorisation records.

3.1.4 SetRoamingAuthorisationList.conf

This contains the field definition of the SetRoamingAuthorisationList.conf sent by the CHS as response to the SetRoamingAuthorisationList.req.

Field Name	Field Type	Card.	Description
result	Result	1	This contains the result of SetRoamingAuthorisationList.req.
refusedRoamingAuthorisationInfo	RoamingAuthorisationInfo	?	This contains the roaming authorisation records that could not be set in the clearing house. For error description see the result message.

3.1.5 GetRoamingAuthorisationListUpdates.req

This contains the field definition of the GetRoamingAuthorisationListUpdate.req sent by a partner's system to the CHS.

Field Name	Field Type	Card.	Description
lastUpdate	DateTimeType	1	Date and time since the last successful call of GetRoamingAuthorisationList.req or GetRoamingAuthorisationListUpdate.req.

3.1.6 GetRoamingAuthorisationListUpdates.conf

This contains the field definition of the GetRoamingAuthorisationListUpdate.conf sent by the CHS as response to the GetRoamingAuthorisationListUpdate.req.

Field Name	Field Type	Card.	Description
result	Result	1	This contains the result of GetRoamingAuthorisationListUpdate.req.
roamingAuthorisationInfoArray	RoamingAuthorisationInfo	*	This contains the roaming authorisation records changed since the time specified in lastUpdate in the request.

3.1.7 UpdateRoamingAuthorisationList.req

This contains the field definition of the UpdateRoamingAuthorisationList.req sent by a partner's system to the CHS.

Field Name	Field Type	Card.	Description
roamingAuthorisationInfoArray	RoamingAuthorisationInfo	+	This contains the roaming authorisation records to be updated or added.

3.1.8 UpdateRoamingAuthorisationList.conf

This contains the field definition of the UpdateRoamingAuthorisationList.conf sent by the CHS as response to the UpdateRoamingAuthorisationList.req.

Field Name	Field Type	Card.	Description
result	Result	1	This contains the result of UpdateRoamingAuthorisationList.req.
refusedRoamingAuthorisationInfo	RoamingAuthorisationInfo	?	This contains the roaming authorisation records that could not be set in the clearing house. For error description see the result message.

3.2 Messages for the Exchange of Charge Data

These messages are used for the purpose of the exchange of charge data from an EVSE Operator to an EVSP.

3.2.1 GetCDRs.req

This contains the field definition of the GetCDRs.req sent by a partner's system to the CHS.

No fields are defined.

3.2.2 GetCDRs.conf

This contains the field definition of the GetCDRs.conf sent by the CHS as response to the GetCDRs.req.

Field Name	Field Type	Card.	Description
result	Result	1	This contains the result of GetCDRs.req.
cdrInfoArray	Array(CDRInfo)	*	This contains the CDRs that have been cleared (in the last call to ClearCDRs.req).

3.2.3 AddCDRs.req

This contains the field definition of the AddCDRs.req sent by a partner's system to the CHS.

Field Name	Field Type	Card.	Description
cdrInfoArray	Array(CDRInfo)	+	This contains one or more Charge Detail Records.

3.2.4 AddCDRs.conf

This contains the field definition of the AddCDRs.conf sent by the CHS as response to the AddCDRs.req.

Field Name	Field Type	Card.	Description
result	Result	1	This contains the result of AddCDRs.req.
implausibleCdrsArray	Array(CDRInfo)	*	This contains the refused Charge Detail Records.

3.2.5 ConfirmCDRs.req

This contains the field definition of the ConfirmCDRs.req sent by a partner's system to the CHS.

Field Name	Field Type	Card.	Description
approved	Array(CDRInfo)	*	This contains the CDRs that have been approved by the EVSP.
declined	Array(CDRInfo)	*	This contains the CDRs that have been declined by the EVSP.

3.2.6 ConfirmCDRs.conf

This contains the field definition of the GetCDRs.conf sent by the CHS as response to the ConfirmCDRs.req.

Field Name	Field Type	Card.	Description
result	Result	1	This contains the result of ConfirmCDRs.req.

3.3 Messages for the Exchange of Charge Point Information

These messages are used for the purpose of the exchange of charge point information or POI data from an EVSE Operator to an NSP.

3.3.1 GetChargePointList.req

This contains the field definition of the GetChargePointList.req sent by a partner's system to the CHS.

No fields are defined.

3.3.2 GetChargePointList.conf

This contains the field definition of the GetChargePointList.conf sent by the CHS as response to the GetChargePointList.req.

Field Name	Field Type	Card.	Description
result	Result	1	This contains the result of GetRoamingAuthorisationList.req.
chargePointInfoArray	ChargePointInfo	*	This contains the charge point information records.

3.3.3 SetChargePointList.req

This contains the field definition of the SetChargePointList.req sent by a partner's system to the CHS.

Field Name	Field Type	Card.	Description
chargePointInfoArray	ChargePointInfo	+	This contains the charge point information records.

3.3.4 SetChargePointList.conf

This contains the field definition of the SetChargePointList.conf sent by the CHS as response to the SetChargePointList.req.

Field Name	Field Type	Card.	Description
result	Result	1	This contains the result of SetChargePointList.req.
refusedChargePointInfo	ChargePointInfo	?	This contains the charge point information records that could not be set in the clearing house. For error description see the result message.

3.3.5 GetChargePointListUpdates.req

This contains the field definition of the GetChargePointListUpdates.req sent by a partner's system to the CHS.

Field Name	Field Type	Card.	Description
lastUpdate	DateTimeType	1	Date and time since the last successful call of GetChargePointList.req or GetChargePointListUpdates.req.

3.3.6 GetChargePointListUpdates.conf

This contains the field definition of the GetChargePointListUpdates.conf sent by the CHS as response to the GetChargePointListUpdates.req.

Field Name	Field Type	Card.	Description
result	Result	1	This contains the result of GetChargePointListUpdates.req.
chargePointInfoArray	ChargePointInfo	*	This contains the charge point information records changed since the time specified in lastUpdate in the request.

3.3.7 UpdateChargePointList.req

This contains the field definition of the UpdateChargePointList.req sent by a partner's system to the CHS.

Field Name	Field Type	Card.	Description
chargePointInfoArray	ChargePointInfo	+	This contains the charge point information records to be updated or added.

3.3.8 UpdateChargePointList.conf

This contains the field definition of the UpdateChargePointList.conf sent by the CHS as response to the SetChargePointList.req.

Field Name	Field Type	Card.	Description
result	Result	1	This contains the result of UpdateChargePointList.req.
refusedChargePointInfo	ChargePointInfo	?	This contains the charge point information records that could not be set in the clearing house. For error description see the result message.

3.4 Messages for live authorisation

3.4.1 RequestLiveRoamingAuthorisation.req

This contains the field definition of the RequestLiveRoamingAuthorisation.req sent by CMS to the CHS. A authorisation will always generate a unique cdrId to track the transaction. This ID can be generated by the operator or will be issued by the clearing house.

Field Name	Field Type	Card.	Description
emId	EmId	1	This contains the ID of the token which is to be validated.

Continued on next page...

Field Name	Field Type	Card.	Description
evseId	EvseId	1	Unique identifier for every EVSE following a common scheme with a major id-unit reflecting the country and the market partner issuing it.

3.4.2 RequestLiveRoamingAuthorisation.conf

This contains the field definition of the RequestLiveRoamingAuthorisation.conf sent by the CHS as response to the RequestLiveRoamingAuthorisation.req.

Field Name	Field Type	Card.	Description
result	Result	1	This contains the result of GetRoamingAuthorisationList.req.
roamingAuthorisationInfo	RoamingAuthorisationInfo	?	This contains the roaming authorisation record for the requested token, if the request was valid.
liveAuthId	LiveAuthId	1	Unique ID of the live authorisation request to the clearing house. Must be used for the corresponding CDR to reference this request.

3.5 Messages for the Live Status Interface

3.5.1 UpdateStatus.req

This contains the field definition of the UpdateStatus.req sent by a CMS to the CHS.

Field Name	Field Type	Card.	Description
evse	EvseStatusType	*	This contains one EVSE id with the current status represented in a major part and a minor part.
ttl	DateTimeType	?	The time to live is set as the deadline till the status values are to be considered valid, where not otherwise specified.

3.5.2 UpdateStatus.conf

This contains the field definition of the UpdateStatus.conf sent by the CHS as response to the UpdateStatus.req.

Field Name	Field Type	Card.	Description
result	Result	1	This contains the result of UpdateStatus.req.

3.5.3 GetStatus.req

This contains the field definition of the GetStatus.req sent by a NPS to the CHS.

Field Name	Field Type	Card.	Description
startDateTime	DateTimeType	?	If this value is set to a point in the past the response is limited to status information that is more actual than the given value.

3.5.4 GetStatus.conf

This contains the field definition of the GetStatus.conf sent by the CHS as response to the GetStatus.req.

Field Name	Field Type	Card.	Description
evse	EvseStatusType	*	This contains one EVSE id with the current status represented in a major part and a minor part.

4 Types

The defined types have either to be filled with a valid value or - where allowed - left out in the SOAP tree.

4.1 General Types

These data types are used in two or more use cases of this protocol.

4.1.1 Result

CLASS

Contains result information.

Field Name	Field Type	Card.	Description
resultCode	resultCodeType	1	The machine-readable result code.
resultDescription	string	1	The human-readable error description.

4.1.2 ResultCodeType

ENUMERATION

Result and error codes for the class Result as return value for method calls.

Value	Description
ok	Data accepted and processed.
server	Internal server error.
other	Other error type. See Description for details.
format	Data could not be processed due to formal error in the SOAP message.
missing	A mandatory value was missing.
range	A given value was out of the allowed range.

4.1.3 DateTimeType

Format is according to ISO8601 UTC. The field takes 20 alphanumeric characters.

Example:

2011-06-01T11:45:30Z

Regular Expression:

$(\backslash d\backslash d\backslash d\backslash d) - (\backslash d\backslash d) - (\backslash d\backslash d)T(\backslash d\backslash d) : (\backslash d\backslash d) : (\backslash d\backslash d)Z$

4.1.4 LocalDateTimeType

Format is according to ISO8601 UTC + Offset. The field takes 25 alphanumeric characters.

Example:

2011-06-01T11:45:30+02:00

Regular Expression:

$(\backslash d\backslash d\backslash d\backslash d) - (\backslash d\backslash d) - (\backslash d\backslash d)T(\backslash d\backslash d): (\backslash d\backslash d): (\backslash d\backslash d)([+\-]\backslash d\backslash d): (\backslash d\backslash d)$

4.2 Types for the Exchange of Authorisation Data

These data types are used for the purpose of the exchange of authorisation data from an EVSP to an EVSE Operator.

4.2.1 ContractId (or EVCO-ID)

The data type ContractId must follow the specification for EMAID in *ISO/IEC 15118-2 - Annex H "Specification of Identifiers"*. The check digit is optional but highly recommended. For calculation see *Annex A*.

The EMAID must match the following structure (the notation corresponds to the augmented Backus-Naur Form (ABNF) as defined in RFC 5234):

```
<ContractID> = <Country Code> <S> <Provider ID> <S> <
  Instance> <S> <Check Digit>
```

```
<Country Code> = 2 ALPHA
  ; two character country code according to ISO 3166-1 (
  Alpha-2-Code)
```

```
<Provider ID> = 3 (ALPHA / DIGIT)
  ; three alphanumeric characters, defined and listed by
  eMI3 group
```

```
<Instance> = 9 (ALPHA / DIGIT)
  ; nine alphanumeric characters
```

```
<Check Digit> = *1 (ALPHA / DIGIT)
  ; Optional but highly recommended, see subclause H.1.3
  for its computation
```

```
ALPHA = %x41-5A / %x61-7A
  ; according to IETF RFC 5234 (7-Bit ASCII)
```

```
DIGIT = %x30-39
  ; according to IETF RFC 5234 (7-Bit ASCII)
```

```
<S> = *1 ( "-" )
  ; optional separator
```

An example for a valid EMAID therefore is [DE8AACA2B3C4D5N](#) or with dashes [DE-8AA-CA2B3C4D5-N](#).

Contract-ID Semantics The following rules apply:

- The Contract-ID must be interpreted case insensitive.
- A hyphen ("-") can be used as separator in communication with users to allow better reading, spelling and typing. An example for such an illustration is [DE-8AA-CA2B3C4D5-N](#). If the hyphenated representation is chosen, the separators must be set at all three places.
- Each Contract-ID has a fixed length of at least fourteen and at most fifteen characters excluding the optional hyphens or seventeen respectively eighteen characters including the optional separators.
- While the Provider ID must be assigned by a central issuing authority, each provider with an assigned Provider ID can chose the eMA Instance within the above mentioned rules freely.

Backward Compatibility Contract IDs as defined in DIN SPEC 91286 may be used as well by adding two zeros ("00") at the beginning of the Instance-part and the old check digit at position 14. A second check digit as referenced in this document may be calculated over the resulting ID and may be added on position 15.

Example: The DIN-Contract-ID [DE-8AA-123A56-3](#) must be set as EMAID [DE-8AA-00123A563-N](#).

ID-Structure One Contract-ID (ContractId) may refer to several Token-IDs (EmtId). This reflects the situation that one contractual user account can be authorized by different tokens. The structure can be illustrated as shown in figure 11.

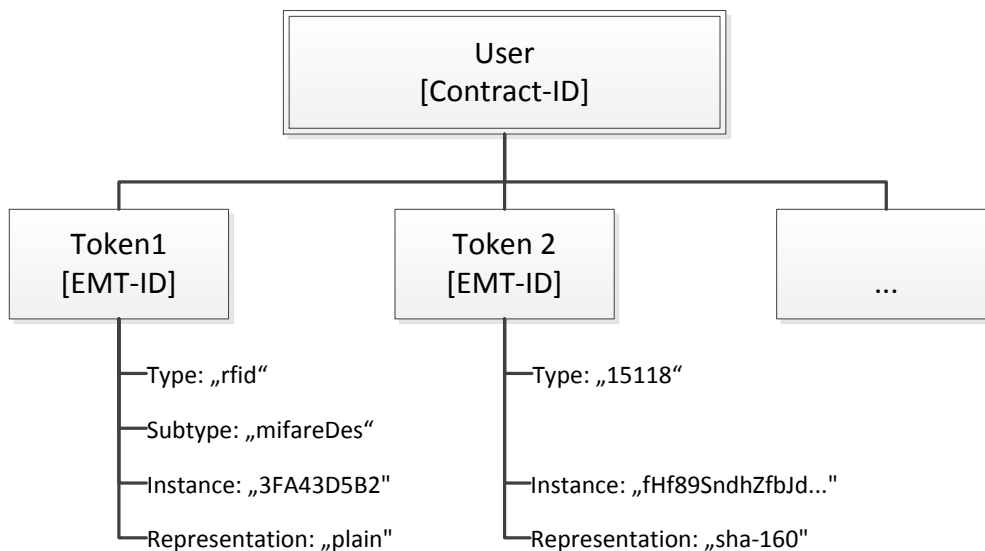

Figure 11: ID-Structure

4.2.2 EmtId

CLASS

The authorisation tokens are defined according to the specification of the EMT-ID (Token ID). Each token consists of an token instance which holds the payload and at least the token type. The sub-type is for further specification of the general token type.

Field Name	Field Type	Card.	Description
instance	string(512)	1	Specification according to the token type.
representation	tokenRepresentation	1	The token instance may be represented by its hash value (hexadecimal representation of the hash value). This specifies in which representation the token instance is set.
type	tokenType	1	The type of the supplied instance.
subType	tokenSubType	?	The exact type of the supplied instance.

4.2.3 tokenType

ENUMERATION

The type of the supplied instance for basic filtering.

Value	Description
rfid	All kinds of RFID-Cards. Field tokenInstance holds the hexadecimal representation of the card's UID, Byte order: big endian, no zero-filling.
remote	All means of remote authentication through the backend.
15118	All authentication means defined by ISO/IEC 15118 except RFID-cards.

4.2.4 tokenSubType

ENUMERATION

The exact type of the supplied instance for referencing purpose.

Value	Description
mifareCls	Mifare Classic Card
mifareDes	Mifare Desfire Card
calypso	Calypso Card

4.2.5 tokenRepresentation

ENUMERATION

Specifies the representation of the token to allow hashed token values.

Value	Description
plain	The token instance is represented in plain text.
sha-160	The token instance is represented in its 160bit SHA1 hash in 40 hexadecimal digits. (default)
sha-256	The token instance is represented in its 256bit SHA2 hash in 64 hexadecimal digits.

eMT-ID Semantics The EMT ID can be used to identify any identification token for e-mobility. The EMT ID is a non-global ID and therefore has no country code or operator/provider part. This information about the "owning operator/provider" is delivered by the context of the communication.

4.2.6 RoamingAuthorisationInfo

CLASS

Contains information about a roaming authorisation (card/token)

Field Name	Field Type	Card.	Description
EmtId	EmtId	1	Electrical Vehicle Contract Identifier
contractId	ContractId	1	EMA-ID the token belongs to.
printedNumber	string(150)	?	Might be used for manual authorisation.
expiryDate	DateTimeType	1	Tokens may be used until the date of expiry is reached. To be handled by the partners systems. Expired roaming authorisations may be erased locally by each partner's systems.

4.3 Types for the Exchange of Charge Data

These data types are used for the purpose of the exchange of charge data from an EVSE Operator to an EVSP.

4.3.1 BillingItemtype

ENUMERATION

The billing items for charging periods.

Value	Description
parkingtime	Price for the time of parking. The billingValue represents the time in hours.
usagetime	Price for the time of EVSE usage. The billingValue represents the time in hours.
energy	Price for the consumed energy. The billingValue represents the energy in kilowatt-hours.
power	Price for the used power level. The billingValue represents the maximum power in kilowatts.
serviceFee	General service fee per charging process. The billingValue represents multiplier and thus has to be set to "1.0".

4.3.2 CdrPeriodType

CLASS

This class defines one time and billing period in the charge detail record. Two periods may overlap in time. Each period represents one billing item of the charging process.

The value *periodCost* is optional and can be calculated from the other values in the period. The calculation of this total cost of one charging period is calculated the following way:

$$periodCost = billingValue \cdot itemPrice [currency]$$

Therefore the total cost C of a charging process and thus the value that has to be paid to the operator is calculated by summing up all period prices:

$$C = \sum_{i=1}^n (\text{billingValue}_i \cdot \text{itemPrice}_i) [\text{currency}]$$

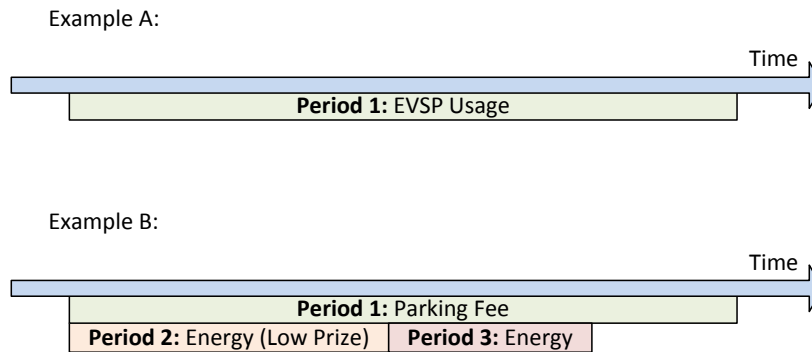

Figure 12: Example for periods in a CDR

Field Name	Field Type	Card.	Description
startDateTime	LocalDateTimeType	1	Starting time of the period. Must be equal or later than startDateTime of the CDRInfo.
endDateTime	LocalDateTimeType	1	Ending time of the period. Must be equal or earlier than endDateTime of the CDRInfo.
billingItem	BillingItemType	1	Defines what the EVSP is charged for during this period.
billingValue	float	1	The value the EVSP is charged for. The unit of this value depends on the billingItem.
currency	string(3)	1	Alphabetic. The displayed and charged currency. Defined in ISO 4217 - Table A.1, alphabetic list.
itemPrice	float	1	Price per unit of the billingItem in the given currency.
periodCost	float	?	Total cost of the period in the given currency.

Implementation Different prices for the individual parts of the pricing model can be reflected by adding multiple periods to one CDR. There are various possible combinations of periods to reflect different pricing models. Some examples:

- There could be a higher price for the first 30 minutes, followed by a lower price. This requires two pricing periods, one for each price level.
- Another operator could charge a start fee per charging session plus the energy price per kilowatt hour. This requires two periods, one of type *serviceFee* and one

of type *energy*, both covering the full length of the charging process.

- Not all roaming relations require rated charge data. If not needed, the *itemPrice* may be set to 0 (zero) to explicitly reflect a roaming process that will not be charged by the operator.

4.3.3 CdrStatusType

ENUMERATION

Reflects the current status of the CDR. This is reflecting the status of internal processing in the clearing house. The value must not be changed by the partner's systems directly. Implicit changes are made while uploading, approving or declining CDRs. Further information in section 2.2 on page 15.

Value	Description
new	A new CDR before upload to the CHS.
accepted	An uploaded CDR was accepted by the CHS as plausible.
rejected	The checked CDR again rejected by the CHS and is to be archived.
owner declined	The CDR was declined by the owner (EVSP).
approved	The CDR was approved by the owner (EVSP).

4.3.4 CDRInfo

CLASS

Contains all information concerning a Charge Data Record

Field Name	Field Type	Card.	Description
cdrId	string(36)	1	Alphanumeric, Charge Data Record number. Unique per EVSE-ID. Characters: [A-Z], [0-9]
evseId	EvseId	1	Unique identifier for every EVSE following a common scheme with a major id-unit reflecting the country and the market partner issuing it.
emtId	EmtId	1	Utilized token for this charging session.
contractId	ContractId	1	Identifies a customer in the electric mobility charging context.
liveAuthId	LiveAuthId	?	References a live authorisation request to the clearing house. Must be specified if the charging process was authorized by the clearing house directly in a call to RequestLiveRoamingAuthorisation.
status	CdrStatusType	1	Current status of the CDR. Must be set to "new" by the issuing CMS. Shall not be changed by any partner but only by the CHS.
startDateTime	LocalDateTimeType	1	Start date and time of the charge session (login with the RFID badge). Local time of the charge point is used.
endDateTime	LocalDateTimeType	1	End date and time of the charge session (log-off with the RFID badge or physical disconnect). Must be set in the local time of the charge point.

Continued on next page...

Field Name	Field Type	Card.	Description
duration	string(9)	?	Duration of the charge session. Example: "000:00:28"
houseNumber	string(6)	?	Hose number at the location of the charge point. Alphanumeric, for example "10","255B"
address	string(45)	?	Street of the location of the charge point. Optionally also containing the house number if not in field houseNumber.
zipCode	string(10)	?	Where available the ZIP code of the location of the charge point.
city	string(45)	?	City of the location of the charge point.
country	string(3)	1	Country of the location of the charge point. Format is according to the three-character ISO-3166 code.
chargePointType	string(2)	1	The type of the charge point "AC" or "DC"
connectorType	ConnectorType	1	Type of the utilized socket or connector.
maxSocketPower	float	1	Maximum available power at the socket in kilowatts. Example: "3.7", "11", "22"
productType	string(2)	?	Identifies the type of the product that was delivered for the charging session. Custom product code.
meterId	string(20)	?	Written identification number of the physical energy meter, provided by the manufacturer. For future use.
chargingPeriods	CdrPeriodType	+	One period per item on the bill. At the moment only one period is to be provided.

4.4 Types for the Exchange of Charge Point Information

These data types are used for the purpose of the exchange of charge point information or POI data from an EVSE Operator to an NSP.

4.4.1 EvseId

The EVSEID must follow the specification of *ISO/IEC 15118-2 - Annex H "Specification of Identifiers"*.

The EVSEID must match the following structure (the notation corresponds to the augmented Backus-Naur Form (ABNF) as defined in RFC5234):

```
<EVSEID> = <Country Code> <S> <EVSE Operator ID> <S>
<ID Type> <Power Outlet ID>
```

```
<Country Code> = 2 ALPHA
; two character country code according to ISO 3166-1 (
Alpha-2-Code)
```

```
<EVSE Operator ID> = 3 (ALPHA / DIGIT)
; three alphanumeric characters, defined and listed by
eMI3 group
```

```

<ID Type> = "E"
    ; one character "E" indicating that this ID represents
    an "EVSE"
<Power Outlet ID> = (ALPHA / DIGIT) *30 (ALPHA / DIGIT / <
    S>)
    ; sequence of alphanumeric characters or separators,
    start with alphanumeric character
ALPHA = %x41-5A / %x61-7A
    ; according to IETF RFC 5234 (7-Bit ASCII)
DIGIT = %x30-39
    ; according to IETF RFC 5234 (7-Bit ASCII)
<S> = *1 ( "*" )
    ; optional separator

```

An example for a valid EVSEID is FR*A23*E45B*78C with FR indicating France, A23 representing a particular EVSE Operator, E indicating that it is of type EVSE and 45B*78C representing one of its power outlets.

EVSEID Semantics

The following rules apply:

- Each EVSEID has a variable length with at least seven characters (two characters Country Code, three characters EVSE Operator ID, one character ID Type, one character Power Outlet ID) and at most thirty-seven characters (two characters Country Code, three characters EVSE Operator ID, one character ID Type, thirty-one characters Power Outlet ID).
- While the EVSE Operator ID shall be assigned by a central issuing authority, each operator with an assigned EVSE Operator ID can choose the Power Outlet ID within the above mentioned rules freely.

Backward Compatibility EVSE-IDs as defined in DIN SPEC 91286 MAY be used by applying the following mapping:

- The two digit country code "49" in Germany for geographic areas in ITU-T E.164:11/2010 is mapped onto the ISO-3166-1 (Alpha-2-Code).
- The three digit of spot operator ID is mapped 1:1 into the new alphanumeric scheme.
- All digits are mapped 1:1 into the new alphanumeric scheme.

Example: *+49*823*1234*5678* is interpreted as *DE*823*E1234*5678*

4.4.2 evselmimeType

CLASS

This class references images related to a EVSE in terms of a file name or uri. According to the roaming connection between one EVSE Operator and one or more Navigation

Service Providers the hosting or file exchange of image payload data has to be defined. The exchange of this content data is out of scope of OCHP. However, the recommended setup is a public available web server hosted and updated by the EVSE Operator. Per charge point a unlimited number of images of each type is allowed. Recommended are at least two images where one is a network or provider logo and the second is a station photo. If two images of the same type are defined they should be displayed additionally, not optionally.

Photo Dimensions The recommended dimensions for all photos are minimum 800 pixels wide and 600 pixels height. Thumbnail representations for photos should always have the same orientation than the original with a size of 200 to 200 pixels.

Logo Dimensions The recommended dimensions for logos are exactly 512 pixels wide and 512 pixels height. Thumbnail representations for logos should be exactly 128 pixels in with and height. If not squared, thumbnails should have the same orientation than the original.

Field Name	Field Type	Card.	Description
uri	string(255)	1	uri from where the image data can be fetched. Must begin with a protocol of the list: http, https, file, ftp. Regex: <code>[A-Za-z][A-Za-z0-9\+\.\-]*:[A-Za-z0-9\+\.\-:\/?#\[\]@!\\$&'(\)*\+\+= %[A-Fa-f0-9]{2})+&</code>
thumbUri	string(255)	?	uri from where a thumbnail of the image can be fetched. Must begin with a protocol of the list: http, https, file, ftp
class	ImageClass	1	Image class for usage categorization
type	string(4)	1	Image type like: gif, jpeg, png, svg
width	int(5)	?	Width of the full scale image
height	int(5)	?	Height of the full scale image

4.4.3 ImageClass

ENUMERATION

The class of a EVSE image to obtain the correct usage in an user presentation. Has to be set accordingly to the image content in order to guaranty the right usage.

Value	Description
networkLogo	logo of a associated roaming network to be displayed with the EVSE for example in lists, maps and detailed information view
operatorLogo	logo of the charge points operator, for example a municipal, to be displayed with the EVSEs detailed information view or in lists and maps, if no networkLogo is present
ownerLogo	logo of the charge points owner, for example a local store, to be displayed with the EVSEs detailed information view
stationPhoto	full view photo of the station in field. Should show the station only
locationPhoto	location overview photo. Should indicate the location of the station on the site or street.
entrancePhoto	location entrance photo. Should show the car entrance to the location from street side

Continued on next page...

Value	Description
otherPhoto	other related photo to be displayed with the stations detailed information view
otherLogo	other related logo to be displayed with the stations detailed information view
otherGraphic	other related graphic to be displayed with the stations detailed information view

4.4.4 GeoPointType

CLASS

This class defines a geo location. The geodetic system to be used is WGS 84.

Field Name	Field Type	Card.	Description
lat	string(10)	1	Latitude of the point in decimal degree. Example: 50.770774. Decimal separator: "." Regex: <code>-?[0-9]{1,2}\.[0-9]{6}</code>
lon	string(11)	1	Longitude of the point in decimal degree. Example: -126.104965. Decimal separator: "." Regex: <code>-?[0-9]{1,3}\.[0-9]{6}</code>

4.4.5 ConnectorStandard

ENUMERATION

The socket or plug standard of the charging point.

Value	Description
CHADEMO	The connector type is CHAdeMO, DC
IEC-62196-T1	IEC 62196 Type 1 "SAE J1772"
IEC-62196-T1-COMBO	Combo Type 1 based, DC
IEC-62196-T2	IEC 62196 Type 2 "Mennekes"
IEC-62196-T2-COMBO	Combo Type 2 based, DC
IEC-62196-T3A	IEC 62196 Type 3A
IEC-62196-T3C	IEC 62196 Type 3C "Scame"
DOMESTIC-A	Standard/Domestic household, type "A", NEMA 1-15, 2 pins
DOMESTIC-B	Standard/Domestic household, type "B", NEMA 5-15, 3 pins
DOMESTIC-C	Standard/Domestic household, type "C", CEE 7/17, 2 pins
DOMESTIC-D	Standard/Domestic household, type "D", 3 pin
DOMESTIC-E	Standard/Domestic household, type "E", CEE 7/5 3 pins
DOMESTIC-F	Standard/Domestic household, type "F", CEE 7/4, Schuko, 3 pins
DOMESTIC-G	Standard/Domestic household, type "G", BS 1363, Commonwealth, 3 pins
DOMESTIC-H	Standard/Domestic household, type "H", SI-32, 3 pins
DOMESTIC-I	Standard/Domestic household, type "I", AS 3112, 3 pins
DOMESTIC-J	Standard/Domestic household, type "J", SEV 1011, 3 pins
DOMESTIC-K	Standard/Domestic household, type "K", DS 60884-2-D1, 3 pins
DOMESTIC-L	Standard/Domestic household, type "L", CEI 23-16-VII, 3 pins
TESLA-R	Tesla Connector "Roadster"-type (round, 4 pin)

Continued on next page...

Value	Description
TESLA-S	Tesla Connector "Model-S"-type (oval, 5 pin)
IEC-60309-2-single-16	IEC 60309-2 Industrial Connector single phase 16 Amperes (usually blue)
IEC-60309-2-three-16	IEC 60309-2 Industrial Connector three phase 16 Amperes (usually red)
IEC-60309-2-three-32	IEC 60309-2 Industrial Connector three phase 32 Amperes (usually red)
IEC-60309-2-three-64	IEC 60309-2 Industrial Connector three phase 64 Amperes (usually red)

4.4.6 ConnectorFormat

ENUMERATION

The format of the connector, whether it is a socket or a plug.

Value	Description
Socket	The connector is a socket; the EV user needs to bring a fitting plug.
Cable	The connector is a attached cable; the EV users car needs to have a fitting inlet.

4.4.7 ConnectorType

CLASS

This class defines a power outlet at an EVSE in terms of its connector standard and format (socket/cable).

Field Name	Field Type	Card.	Description
connectorStandard	ConnectorStandardType	1	The standard of the installed connector.
connectorFormat	ConnectorFormatType	1	The format (socket/cable) of the installed connector.

4.4.8 AuthMethodType

ENUMERATION

The authorisation and payment methods available at an EVSE for the EV user

Value	Description
Public	Public accessible, no authorisation required.
LocalKey	A key or access token can be received at the location. (i.e. at the hotel reception or in the restaurant)
DirectCash	The EVSE can be accessed through direct payment in cash.
DirectCreditcard	The EVSE can be accessed through direct payment with credit card.
DirectDebitcard	The EVSE can be accessed through direct payment with debit card.
RfidMifareCls	Personal RFID token with roaming relation. (Mifare classic)
RfidMifareDes	Personal RFID token with roaming relation. (Mifare Desfire)
RfidCallypso	Personal RFID token with roaming relation. (Calypso)
Iec15118	In-car access token as specified in IEC-15118.

4.4.9 ChargePointStatusType

ENUMERATION

This value represents the overall status of a charging point. Not to be confused with a live status (available, reserved, occupied, ...)

Value	Description
Unknown	No status information available
Operative	charge point is in operation and can be used
Inoperative	charge point cannot be used due to maintenance, failure or other access restrictions (temporarily)
Planned	planned charge point, will be operating soon
Closed	discontinued charge point, will be deleted soon

4.4.10 ChargePointScheduleType

CLASS

This type is used to schedule status periods in the future. The NSP can provide this information to the EV user for trip planning purpose. A period MAY have no end. Example: "This station will be running from tomorrow. Today it is still planned and under construction."

Field Name	Field Type	Card.	Description
startDate	DateTimeType	1	Begin of the scheduled period.
endDate	DateTimeType	?	End of the scheduled period, if known.
status	ChargePointStatusType	1	Status value during the scheduled period.

4.4.11 HoursType

CLASS

Opening and access hours for the charge point.

Field Name	Field Type	Card.	Description
regularHours	regularHoursType	*	Regular hours, weekday based. Should not be set for representing 24/7 as this is the most common case.
exceptionalOpenings	exceptionalPeriodType	*	Exceptions for specified calendar dates, time-range based. Periods the station is operating/accessible. Additional to regular hours. May overlap regular rules.
exceptionalClosings	exceptionalPeriodType	*	Exceptions for specified calendar dates, time-range based. Periods the station is not operating/accessible. Overwriting regularHours and exceptionalOpenings. Should not overlap exceptionalOpenings.

Example one Operating 24/7 except for New Year 2015:

```
<operatingTimes>
  <regularHours>
</operatingTimes>
```

Example two Operating on Weekdays from 8am till 8pm with one exceptional opening on 22/6/2014 and one exceptional closing the Monday after:

```
<operatingTimes>
  <regularHours weekday="1" periodBegin="08:00"
    periodEnd="20:00">
  <regularHours weekday="2" periodBegin="08:00"
    periodEnd="20:00">
  <regularHours weekday="3" periodBegin="08:00"
    periodEnd="20:00">
  <regularHours weekday="4" periodBegin="08:00"
    periodEnd="20:00">
  <regularHours weekday="5" periodBegin="08:00"
    periodEnd="20:00">
  <exceptionalOpenings
    periodBegin="2014-06-21T09:00:00Z" periodEnd="
    2014-06-21T12:00:00Z">
  <exceptionalClosings
    periodBegin="2014-06-24T00:00:00Z" periodEnd="
    2014-06-25T00:00:00Z">
</operatingTimes>
```

This represents the following schedule, where ~~stroked-out~~ days are without operation hours, **bold** days are where exceptions apply and regular displayed days are where the regular schedule applies.

Weekday	Mo	Tu	We	Th	Fr	Sa	Su	Mo	Tu	We	Th	Fr	Sa	Su
Date	16	17	18	19	20	21	22	23	24	25	26	27	28	29
Open from	08	08	08	08	08	09	-	08	-	08	08	08	-	-
Open till	20	20	20	20	20	12	-	20	-	20	20	20	-	-

4.4.12 RegularHoursType

CLASS

Regular recurring operation or access hours

Field Name	Field Type	Card.	Description
weekday	int(1)	1	Regular hours, weekday based. Number of day in the week, from Monday (1) till Sunday (7)
periodBegin	string(5)	1	Begin of the regular period given in hours and minutes. Must be in 24h format with leading zeros. Example: "18:15". Hour/Minute separator: ":" Regex: [0-2][0-9]:[0-5][0-9]

Continued on next page...

Field Name	Field Type	Card.	Description
periodEnd	string(5)	1	End of the regular period, syntax as for periodBegin. Must be later than periodBegin.

4.4.13 ExceptionalPeriodType

CLASS

Specifies one exceptional period for opening or access hours.

Field Name	Field Type	Card.	Description
periodBegin	DateTimeType	1	Begin of the exception.
periodEnd	DateTimeType	1	End of the exception.

4.4.14 ParkingRestrictionType

ENUMERATION

This value, if provided, represents the restriction to the parking spot for different purposes.

Value	Description
evonly	reserved parking spot for electric vehicles
plugged	parking allowed only while plugged in (charging)
disabled	reserved parking spot for disabled people with valid ID
customers	parking spot for customers/guests only, for example in case of a hotel or shop
motorcycles	parking spot only suitable for (electric) motorcycles or scooters

4.4.15 ChargePointInfo

CLASS

Contains information about the charge points.

Field Name	Field Type	Card.	Description
evseId	EvseId	1	Globally unique identifier
locationId	string(15)	1	Alphanumeric. Identifies a location/pool of EVSEs. Unique within one EVSE Operator. Characters: [A-Z], [0-9], <space>
timestamp	DateTimeType	?	Recommended. Date and time of the latest data update for this ChargePointInfo. When set it must be updated if one of the values changed.
locationName	string(100)	1	Official name; should be unique in the geographical area
locationNameLang	string(3)	1	Alpha, three characters. ISO-639-3 language code defining the language of the location name
images	evseImageUrlType	?	Links to images related to the EVSE such as photos or logos.

Continued on next page...

Field Name	Field Type	Card.	Description
houseNumber	string(6)	?	Alphanumeric, for example "10", "255B". Characters: [A-Z], [0-9], <space>
address	string(45)	1	Alphanumeric, for example "Av. Saint-Jean". Optionally also containing the house number if not in field houseNumber.
city	string(45)	1	Alphabetic, in the language defined in locationNameLang
zipCode	string(10)	1	Alphanumeric, Examples: "60439", "8011 PK". Without leading country code. Characters: [A-Z], [0-9], -, <space>
country	string(3)	1	Alpha, three characters. ISO 3166 country code
geoLocation	GeoPointType	1	Geographical location of the charge point itself (power outlet).
geoUserInterface	GeoPointType	?	Geographical location of the user interface for authorisation and payment means. If not specified the user interface is assumed to be at the location specified in geoLocation.
geoSiteEntrance	GeoPointType	*	For larger sites entrances may be specified for navigation.
geoSiteExit	GeoPointType	*	For larger sites exits may be specified for navigation purpose. If only entrances are set, two-direction traffic is assumed.
operatingTimes	HoursType	?	The times the EVSE is operating and can be used for charging. Must not be provided if operating hours are unsure/unknown.
accessTimes	HoursType	?	The times the EVSE is accessible, if different from operatingTimes. For example if a car park is closed during the night. Must not be provided if access hours are unsure/unknown.
status	ChargePointStatusType	?	The current status of the charge point.
statusSchedule	ChargePointScheduleType	*	Planned status changes in the future. If a time span matches with the current or displayed date, the corresponding value overwrites <i>status</i> .
telephoneNumber	string(20)	?	Numeric. Service hotline to be displayed to the EV user. Separators recommended. Characters: [0-9], -, <space>
floorLevel	string(4)	?	Alphanumeric. Level on which the charging station is located (in garage buildings) in the locally displayed numbering scheme. Examples: "-2", "P-5", "+5". Characters: [A-Z], [0-9], -, +, /
parkingSlotNumber	string(5)	?	Alphanumeric. Locally displayed parking slot number. Examples: "10", "B25", "P-234". Characters: [A-Z], [0-9], -, +, /
parkingRestriction	ParkingRestrictionType	*	Those parking restrictions apply to the parking spot.
authMethods	AuthMethodType	+	List of available payment or access methods on site.

Continued on next page...

Field Name	Field Type	Card.	Description
connectors	ConnectorType	+	Which receptacle type is/are present for a power outlet.
userInterfaceLang	string(3)	*	Alpha, three characters. Language(s) of the user interface or printed on-site instructions. <i>ISO-639-3</i> language code

4.5 Types for live authorisation

The following types are used in the live authorisation methods. For referencing purpose the types may also be used in the Charge Detail Record.

4.5.1 LiveAuthId

CLASS

Unique ID for one live authorisation request to the clearing house. Will be returned from a call to RequestLiveRoamingAuthorisation and must be sent back to the clearing house in the corresponding CDRInfo item.

Field Name	Field Type	Card.	Description
liveAuthId	string(15)	1	Unique ID for one live authorisation request to the clearing house.

Additionally to the internal session ID that has to be issued by the operator to uniquely identify the charging process in the CDR, the *liveAuthId* is identifying the live authorisation session in the clearing house. Therefore the *liveAuthId* has be referenced in the CDR to close this session. Figure illustrates the full exchange path of of both IDs.

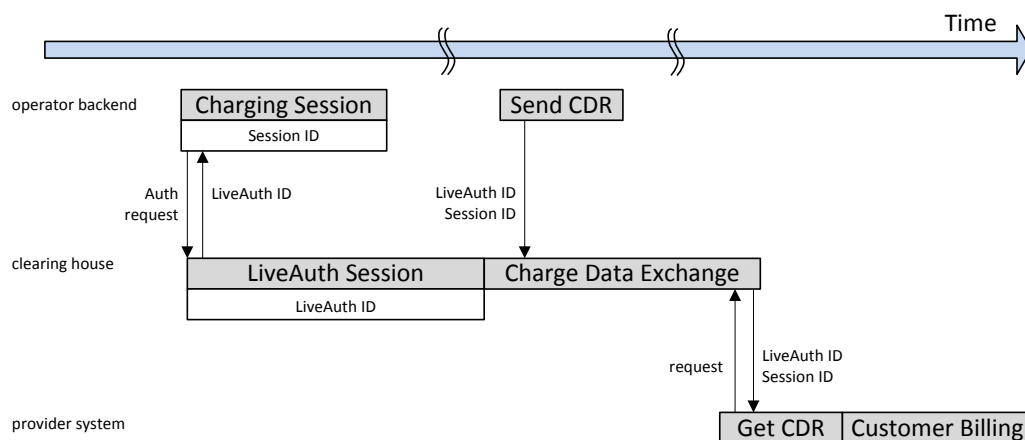

Figure 13: ID handling for the live authorisation request

4.6 Types for the Live Status Interface

These data types are used for the purpose of the exchange of live status information in addition to the charge point information or POI data from an EVSE Operator to an NSP.

4.6.1 MajorType

ENUMERATION

The major status type reflects the overall status of the EVSE.

Value	Description
available	the EVSE is able to start a new charging process
not-available	at the moment no new charging process may be started
unknown	the current status of the EVSE is not known

4.6.2 MinorType

ENUMERATION

The optional minor status type reflects the detailed status of the EVSE in addition to the major status. For each minor status value a proposed ttl value is given. However, the ttl should only be set to a value other than default if the expected status change is known or can be predicted.

Value	Description
available	the EVSE is able to start a new charging process
reserved	the EVSE is able to start a new charging process for limited duration as a future reservation is present. ttl to be set on the start of the reservation when in future or to the end of the reservation else
charging	the EVSE is in use. ttl to be set on the expected end of the charging process
blocked	the EVSE not accessible because of a physical barrier, i.e. a car
outoforder	the EVSE is currently out of order. ttl to be set to the expected re-enabling

4.6.3 EvseStatusType

CLASS

Specifies the major and minor status of a EVSE as defined in 10 on page 19.

Field Name	Field Type	Card.	Description
evseId	EvseId	1	The EVSE the status is set for.
major	MajorType	1	The major status value for the EVSE.
minor	MinorType	?	The minor status value for the EVSE.
ttl	DateTimeType	?	The time to live is set as the deadline till the status value is to be considered valid. Should be set to the expected status change.

5 Binding to Transport Protocol

This section describes how the CHS PDUs can be conveyed over SOAP.

The rationale behind using SOAP as a transport is that SOAP already provides the infrastructure of sending messages. SOAP has a good support in the industry, which results in tools that improve the ease of implementing the protocol.

For this protocol the SOAP Version 1.2 **MUST** be used.

5.1 User Identification

Authentication must be done via WS-Security Username Token within the SOAP Header. The Password is specified as "passwordText".

Example:

```
<soapenv:Envelope xmlns:ns="urn://stationoperator/charging
  /ws/2012/11/" xmlns:soapenv="http://schemas.xmlsoap.org
  /soap/envelope/">

<soapenv:Header>

<wsse:Security soapenv:mustUnderstand="1" xmlns:wsse="http
  ://docs.oasis-open.org/wss/2004/01/oasis-200401-wss-
  wssecurity-secext-1.0.xsd">
<wsse:UsernameToken wsu:Id="UsernameToken-1" xmlns:wsu="
  http://docs.oasis-open.org/wss/2004/01/oasis-200401-wss
  -wssecurity-utility-1.0.xsd">
<wsse:Username>theUsername</wsse:Username>
<wsse:Password Type="http://docs.oasis-open.org/wss
  /2004/01/oasis-200401-wss-username-token-profile-1.0#
  PasswordText">thePassword</wsse:Password>
</wsse:UsernameToken>
</wsse:Security>

</soapenv:Header>
<soapenv:Body>...
```

6 Annexes

6.1 ID Validation and Transformation Tools

6.1.1 Regular expression for EVSE-ID validation

This will match on a valid EVSE-ID. The positive look ahead at the very end has to be changed depending on the usage or implementation.

Regular Expression:

```
[A-Z]{2}(?)[A-Z0-9]{3}(?:\2)[E][A-Z0-9][A-Z0-9]{0,30}(?=\s)
```

6.1.2 Regular expression for Contract-ID validation

This will match on a valid Contract-ID. The positive look ahead at the very end has to be changed depending on the usage or implementation. The check digit has to be validated in a separate step.

Regular Expression:

```
[A-Za-z]{2}(-?)[A-Za-z0-9]{3}(?:\2)[Cc][A-Za-z0-9]{9}(?:\2)[A-Za-z0-9]?(?=\s)
```

6.1.3 Regular expression for Contract-ID normalization

This will remove the optional separators from a valid Contract-ID.

Regular Expression:

```
([A-Za-z]{2})(-?)([A-Za-z0-9]{3})(?:\2)[Cc]([A-Za-z0-9]{9})(?:\2)([A-Za-z0-9])?(?=\s)  
\1\3\4\5\6
```

6.2 List of examples for valid Contract-Ids

These are different possibilities for syntactically correct Contract-IDs.

<i>DE-8AC-C12E456L89-Y</i>	Separators, Upper Case, Check Digit
<i>DE-8AC-C12E456L89</i>	Separators, Upper Case
<i>de-8ac-c12e456l89-y</i>	Separators, Lower Case, Check Digit
<i>de-8ac-c12e456l89</i>	Separators, Lower Case
<i>dE-8Ac-C12e456L89-y</i>	Separators, Mixed Case, Check Digit
<i>De-8aC-c12E456l89</i>	Separators, Mixed Case
<i>DE8ACC12E456L89Y</i>	Upper Case, Check Digit
<i>DE8ACC12E456L89</i>	Upper Case
<i>de8acc12e456l89y</i>	Lower Case, Check digit
<i>de8acc12e456l89</i>	Lower Case
<i>dE8aCc12E456l89Y</i>	Mixed Case, Check Digit
<i>De8AcC12e456L89</i>	Mixed Case

6.3 Data Field Mapping to OCPP

6.3.1 Connector Types

OCHP-Value	OCPP-Value	OCPP-Description
n/a	Avcon	Avcon connector
<i>multiple choices</i>	Domestic	Domestic plug
n/a	IEC60309_2P	60309 Industrial 2P (DC)
n/a	IEC60309_3PE	60309 Industrial 3P + E (AC)
<i>multiple choices</i>	IEC60309_3PEN	60309 Industrial 3P + E + N (AC)
IEC-60309-2-single-16	IEC60309_PNE	60309 Industrial P + N + E (AC)
IEC-62196-T1	IEC62196_1	Type 1 Yazaki
IEC-62196-T2	IEC62196_2	Type 2 Mennekes
IEC-62196-T3C	IEC62196_3	Type 3 Scame
n/a	LPI	Large Paddle Inductive
n/a	NEMA5_20	
IEC-62196-T1	SAEJ1772	Yazaki
n/a	SPI	Small Paddle Inductive
CHADEMO	Tepeco	CHAdeMO fast charging
<i>multiple choices</i>	Tesla	Tesla connector
n/a	Unspecified	
IEC-62196-T1-COMBO	n/a	Not distinguished
IEC-62196-T2-COMBO	n/a	Not distinguished
IEC-62196-T3A	n/a	Not distinguished
DOMESTIC-A	n/a	Not distinguished
DOMESTIC-B	n/a	Not distinguished
DOMESTIC-C	n/a	Not distinguished
DOMESTIC-D	n/a	Not distinguished
DOMESTIC-E	n/a	Not distinguished
DOMESTIC-F	n/a	Not distinguished
DOMESTIC-G	n/a	Not distinguished
DOMESTIC-H	n/a	Not distinguished
DOMESTIC-I	n/a	Not distinguished
DOMESTIC-J	n/a	Not distinguished
DOMESTIC-K	n/a	Not distinguished
DOMESTIC-L	n/a	Not distinguished
TESLA-R	n/a	Not distinguished
TESLA-S	n/a	Not distinguished
IEC-60309-2-three-16	n/a	Not distinguished
IEC-60309-2-three-32	n/a	Not distinguished
IEC-60309-2-three-64	n/a	Not distinguished

6.4 EVSE Infrastructure Model

The interface described in this protocol is defined on EVSE level. However, there are more data structure layers to be considered in the connected systems. To allow for correct mapping to other data structures the following reference is provided. Visualisations of different charging stations are given in the section below.

6.4.1 Data Model Structure

The reference structure for charge point data is shown in figure 14. This hierarchical model maps the entities connector, charge point (or EVSE), charging station and EVSE Operator in four levels. The physical charge pole as a common casing for one multiple charge points is explicitly excluded from the model. The physical combination of multiple charge points in one pole is not affecting the logical relation of those. However, the attributes of the EVSE level may indicate to its existence when two EVSEs share a common user interface.

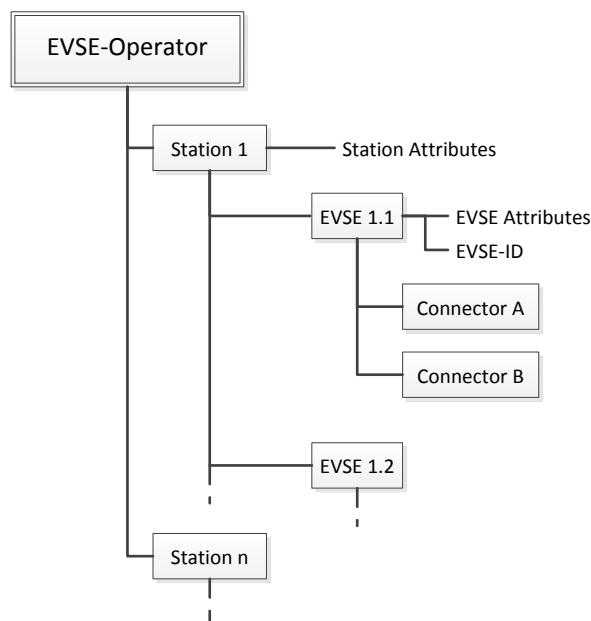

Figure 14: EVSE Data Model Structure

The architecture of the data model is based on the logical relations of the entities with a focus on the use cases for the EV user. The electrical connection of charge points, for example, is not influencing the data structure.

Each entity may have certain attributes attached. For the mapping to the OCHP data types and messages, the common attributes of parent entities are attached to the EVSE level. This results in repetitive data but allows maximum in flexibility. Most noteworthy consequences from this data structure are the fact, that all EVSEs in one station should be managed by the same operator and that all charge points of one station should physically be situated in next to each other. It is also necessary that all Navigation Service

Provider backends and data models are able to assign multiple connectors to one charge point.

Depending on the use case, different inheritance and aggregation of attributes is possible or may be necessary. For example requires the search for a available charging station to find one single available EVSE, what is relatively simple with the flat OCHP data model. If in another use case the search for a station with at least two available EVSEs is required, a aggregation of the data to the station level might be useful.

Please note that other layers might exist or be added in the future.

6.4.2 Examples

In order to visualize the different possible situations of supply equipment, this section contains some examples. Of course not all possible cases can be reflected. As OCHP is not modelling the full data structure but only the EVSE level, the aggregation to the higher and lower levels has to be performed in the connected systems. This allows high flexibility in the different data models. The used symbols in the examples as shown in figure 15 are:

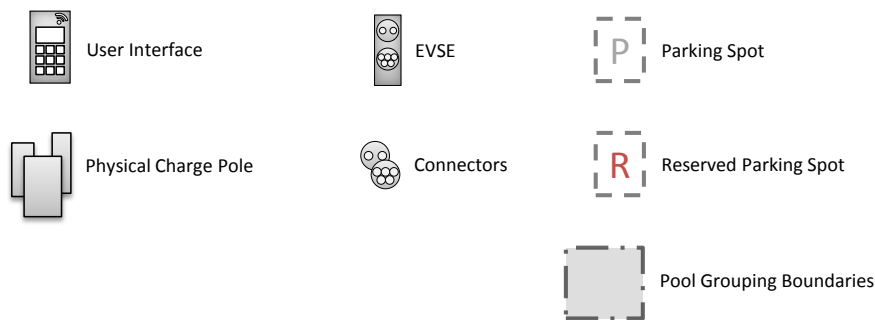

Figure 15: Symbols used in example figures

User Interface is used by the EV User to interact with the charging station in terms of authorisation, authentication, payment or charging process controlling purpose. Common examples for a user interface is a RFID card reader and a display. Also a keypad and direct payment methods are possible additions.

Physical Charge Pole is the case mounted on the location. In the scope of this protocol there is no distinction between wall-mounted and stand-alone charge poles. Even other concepts are possible but do not interfere the data model.

EVSE is one charge point that can independently be used for EV charging. It may host one or multiple connectors which can be used exclusively.

Connector is the physical power outlet the electric vehicle is connected to. May also be inductive.

Parking Spot offers space for exactly one car. Depending on the location and physical constraints like the cable, it is possible to assign one parking spot to multiple charge points.

Reserved Parking Spot is for a dedicated user group only. Common examples are company fleet cars or car sharing cars.

Pool Grouping Boundaries illustrate the virtual grouping of multiple EVSEs to one pool.

Example One (figure 16) is showing one charging station (at one postal address) which itself consists of one physical charge pole. This pole holds two EVSEs or charge points for simultaneous use. Each of those EVSEs offers two different connectors of different type. Those can be used exclusively only. The two EVSEs can be accessed through a mutual user interface. For each EVSE one single parking spot is reserved.

This example represents the most common case for public charging stations. The charging station consists of one single charge pole only. Therefore there is a risk to confuse the terms pole and station. The following examples will make the difference clear.

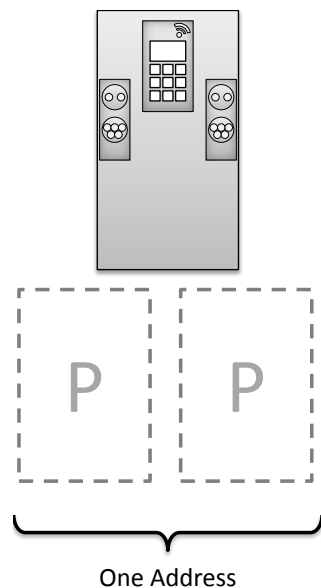

Figure 16: Example 1

Example Two (figure 17) is showing two charging stations (at two different postal addresses) of which each consists of one physical charge pole. Each of those poles holds two EVSEs or charge points for simultaneous use. Each of those EVSEs offers two different connectors of different type. Those can be used exclusively only. The two EVSEs can be accessed through a mutual user interface. For each EVSE one single parking spot is reserved.

In fact, the two charging stations in this example are just exactly two times example one. Each of the stations is placed at a individual location not related to each other.

Example Three (figure 18) is showing one charging station (at one postal address) which consists of two physical charge poles. Each of those poles holds two EVSEs

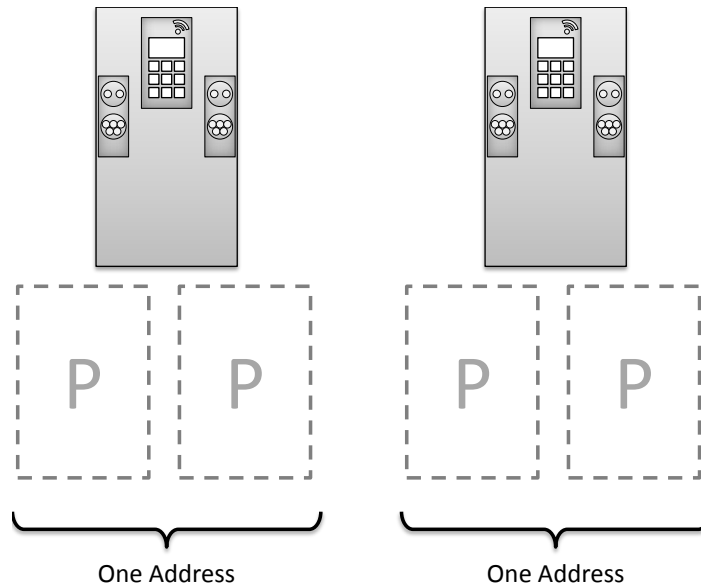

Figure 17: Example 2

or charge points for simultaneous use. Each of those EVSEs offers two different connectors of different type. Those can be used exclusively only. The two EVSEs can be accessed through a mutual user interface. For each EVSE one single parking spot is reserved. The charging station can be utilized by four cars simultaneously as it has four EVSEs and hence has four parking spots in total.

In contrast to example two, both charge poles are located close to each other at the same postal address. Therefore they are communicated as one single charging station to the user. Other circumstances like a common electrical connection or a mutual controlling and communication unit is not decisive for this combination.

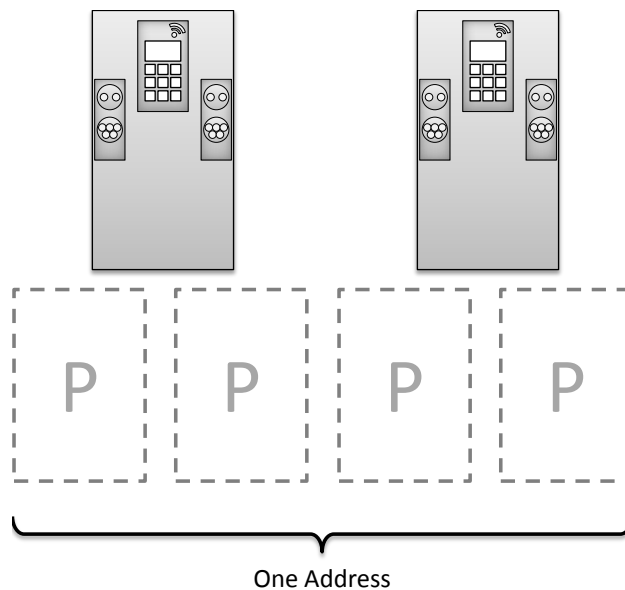

Figure 18: Example 3

Example Four (figure 19) is showing one charging station (at one address) which consists of four physical charge poles. Each of those poles holds one EVSE or charge point for simultaneous use. Each of those EVSEs offers two different connectors of different type. Those can be used exclusively only. All four EVSEs of the four charge poles can be accessed through a mutual user interface, installed in a separate pole at the charging station. For each EVSE one single parking spot is reserved. The charging station can be utilized by four cars simultaneously as it has four EVSEs and hence has four parking spots in total.

This example is similar to the previous example three. This one charging station may be communicated to the user under one single name. In the attributes for the station the user will find the number of charge points which is the same as in example three.

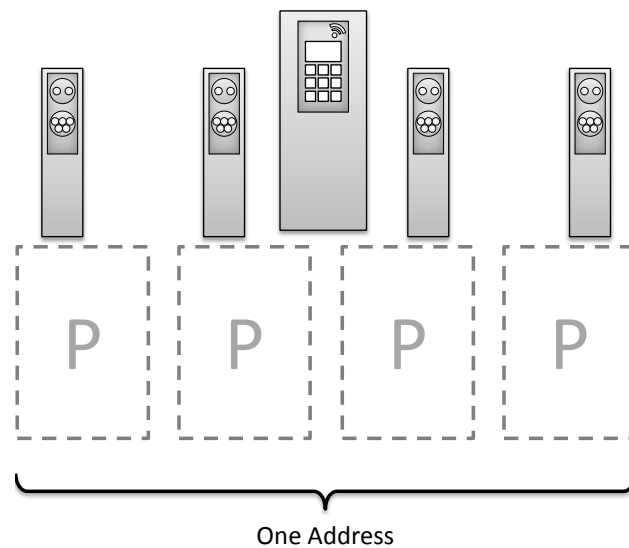

Figure 19: Example 4

6.5 Charge Point Information Filtering

The Navigation Service Provider displays charging point information to the EV User. Usually not all charge points are relevant for every user. The most common case is to display only compatible stations to the car that have at least one available charge point. To gain a mutual understanding of the different filtering steps between the EVSE Operator and the NSP, the following description is provided.

Every charge point is represented by a static data set (*ChargePointInfo*) and additional dynamic data (*EvseStatusType*). The filtering for compatible charge points close to the current location of the EV user is performed on the static data which may be stored locally on the navigation device. In a second step the result may be filtered for current availability.

Preface Based on the characteristics of the user's car and other preferences as well as the current location, a set of possible charge points can be determined. Based on such a set the further filtering for currently available charge points is described in figure 20. The six steps are:

- A** All charge points that are not operative for various reasons are to be removed from the set. (status \neq Operative)
- B** Charge points that have no regular operating hours at the current moment are to be removed from the set. (now \notin operatingTimes.regularHours)
- C** Charge points that have a exceptional closing at the current moment are to be removed from the set. (now \in operatingTimes.exceptionalClosings)
- D** Those charge points from step *B* that have exceptional openings have to be re-added to the set. (now \in operatingTimes.exceptionalOpenings)
- E** All other charge points that remain in the set and the charge points from step *D* are considered operative and accessible at the current moment and may be tested for availability.
- F** Charge points with a live status value other than *Available* are to be removed. (liveStatus \neq Available)

The remaining charge points in the data set are operative and available at the current moment and can be displayed to the EV User.

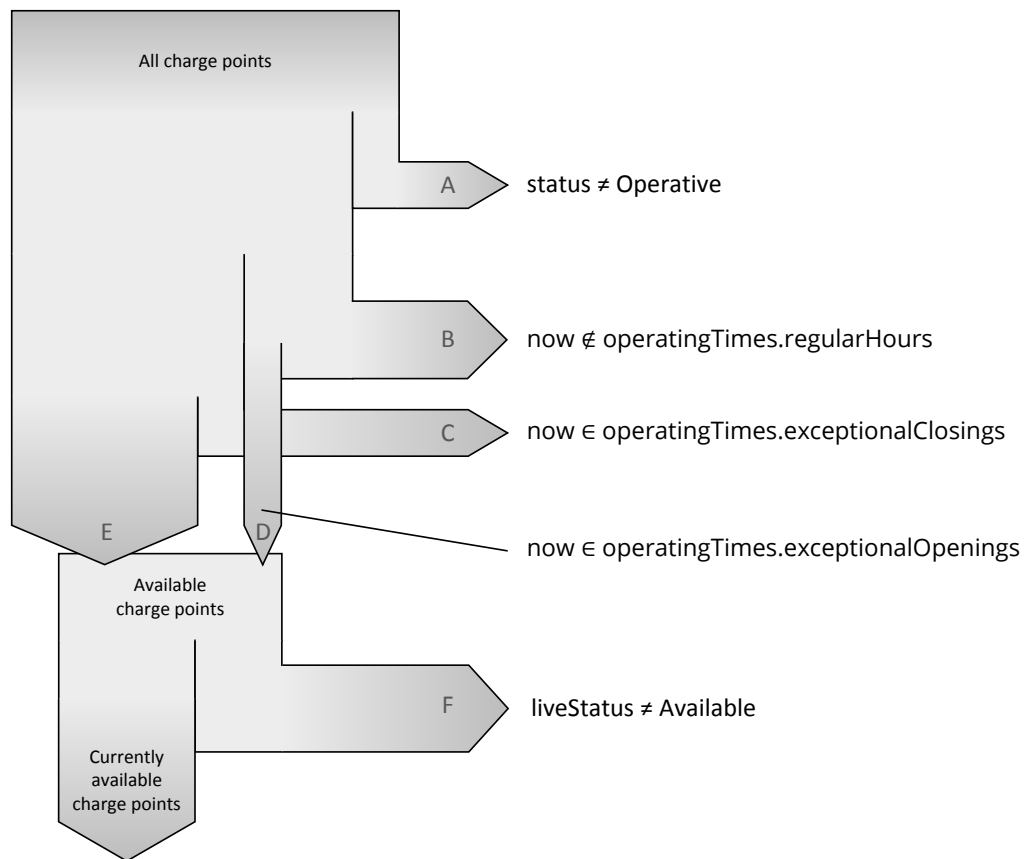

Figure 20: Filtering for available charge points